



**WACKER
NEUSON**
all it takes!

Operator's manual

Vibration plate

VP



Machine Type	VP
Material number	5100056064
Version	1.0
Date	02/2020
Language	[en]



5 1 0 0 0 5 6 0 6 4

Imprint

Publisher and copyright holder:

Wacker Neuson Produktion GmbH & Co. KG

Wackerstraße 6

85084 Reichertshofen, Germany

Registered office: Reichertshofen

Register court and number: Local Court Ingolstadt, HRA3195

VAT ID No./VAT Number: DE277138620

Telephone: +49 (0) 8453-3403200

www.wackerneuson.com

Original operator's manual

All rights reserved, in particular the copyright, the right of reproduction and the right of distribution applicable worldwide.

This document may be used by the recipient only for the designated purpose. It may in no way be duplicated or translated in any other language, in whole or in part, without prior permission in writing from the manufacturer.

Reproduction or translation of this publication, in whole or part, is not permitted without the written consent of Wacker Neuson Produktion GmbH & Co. KG.

Violations of legal regulations, in particular of the copyright protection, will be subject to civil and criminal prosecution.

Wacker Neuson Produktion GmbH & Co. KG reserves the right to change its products and their technical specifications for further technical development at any time without any claim to changes to machines already delivered. The information in the technical documentation supplied with the product applies in each case.

The machine on the cover is for illustration purposes only and may therefore have special equipment (options).

Wacker Neuson Produktion GmbH & Co. KG, responsibility for errors or omissions not accepted, printed in Germany

Copyright © 2020

Contents

1	EC Declaration of Conformity	
2	Preface	
2.1	Introduction	9
2.2	Storage location of the operator's manual	9
2.3	Accident prevention regulations.....	10
2.4	Wacker Neuson Contact.....	11
2.5	Labeling on the machine.....	11
2.6	Use of the operator's manual.....	11
3	Usage	
3.1	Designated use	13
3.2	Unintended use.....	13
4	Safety	
4.1	Safety symbols and signal words	14
4.2	Principle	14
4.3	Structural changes	15
4.4	Responsibility of the operator	15
4.5	Obligations of the operator	16
4.6	Qualification of staff	16
4.7	Residual hazards	16
4.8	General safety instructions	16
4.9	Specific safety instructions for vibration plates	18
4.10	Safety features.....	19
4.11	Maintenance	20
5	Description of the machine	
5.1	Scope of delivery	22
5.2	Safety and information labels	22
5.3	Components	23
5.4	Control elements.....	23
6	Transportation	
6.1	Safety instructions for transport	25
6.2	Prerequisites and preparations.....	25
6.3	Lifting the machine.....	25
6.4	Lashing the machine.....	26
7	Commissioning	
7.1	Tests before commissioning	27
7.2	Safety instructions for operation	27
7.3	Putting into operation.....	28
8	Operation	

8.1	Operating the machine	30
8.2	Taking the machine out of operation	30
9	Maintenance	
9.1	Safety instructions for maintenance.....	31
9.2	Maintenance plan	32
9.3	Maintenance work.....	33
10	Malfunctions	
10.1	Troubleshooting	39
11	Decommissioning	
11.1	Temporary decommissioning.....	40
11.2	Final shutdown.....	40
12	Accessories	
12.1	Accessories.....	41
13	Technical data	
13.1	General instructions.....	42
13.2	Noise and vibration data	42
13.3	VP	42
13.4	Combustion engine	46



EC Declaration of Conformity

Manufacturer

Wacker Neuson Produktion GmbH & Co. KG, Wackerstraße 6, D-85084 Reichertshofen
This declaration of conformity is issued under the sole responsibility of the manufacturer.

Product	VP1135
Product type	Vibratory plate
Function of product	Soil compaction
Material number	5100029063, 5100029064, 5100029065, 5100029066
Net installed power	2,6 kW
Measured sound power level	100 dB(A)
Guaranteed sound power level	105 dB(A)

Conformity assessment procedure

2000/14/EC, Annex VIII

Notified body

TÜV Rheinland LGA Products GmbH, Tillystr. 2, D-90431 Nürnberg (NB 0197)

Guidelines and standards

We hereby declare that this product complies with the relevant provisions and requirements of the following directives and standards:

2006/42/EC, 2000/14/EC, 2014/30/EU, EN 500-1:2006 + A1:2009, EN 500-4:2011, EN ISO 13766-1:2018, EN ISO 13766-2:2018

Person responsible for technical documents

Wacker Neuson Produktion GmbH & Co. KG, Wackerstraße 6, D-85084 Reichertshofen

Reichertshofen, 06.12.2019

Helmut Bauer
Managing Director



EC Declaration of Conformity

Manufacturer

Wacker Neuson Produktion GmbH & Co. KG, Wackerstraße 6, D-85084 Reichertshofen
This declaration of conformity is issued under the sole responsibility of the manufacturer.

Product	VP1340
Product type	Vibratory plate
Function of product	Soil compaction
Material number	5100029058, 5100029059, 5100029060, 5100029061, 5100029062
Net installed power	3,6 kW
Measured sound power level	100 dB(A)
Guaranteed sound power level	108 dB(A)

Conformity assessment procedure

2000/14/EC, Annex VIII

Notified body

TÜV Rheinland LGA Products GmbH, Tillystr. 2, D-90431 Nürnberg (NB 0197)

Guidelines and standards

We hereby declare that this product complies with the relevant provisions and requirements of the following directives and standards:

2006/42/EC, 2000/14/EC, 2014/30/EU, EN 500-1:2006 + A1:2009, EN 500-4:2011, EN ISO 13766-1:2018, EN ISO 13766-2:2018

Person responsible for technical documents

Wacker Neuson Produktion GmbH & Co. KG, Wackerstraße 6, D-85084 Reichertshofen

Reichertshofen, 06.12.2019

Helmut Bauer
Managing Director



EC Declaration of Conformity

Manufacturer

Wacker Neuson Produktion GmbH & Co. KG, Wackerstraße 6, D-85084 Reichertshofen
This declaration of conformity is issued under the sole responsibility of the manufacturer.

Product	VP1550
Product type	Vibratory plate
Function of product	Soil compaction
Material number	5100029054, 5100029055, 5100029056, 5100029057, 5100051526
Net installed power	3,6 kW
Measured sound power level	101 dB(A)
Guaranteed sound power level	108 dB(A)

Conformity assessment procedure

2000/14/EC, Annex VIII

Notified body

TÜV Rheinland LGA Products GmbH, Tillystr. 2, D-90431 Nürnberg (NB 0197)

Guidelines and standards

We hereby declare that this product complies with the relevant provisions and requirements of the following directives and standards:

2006/42/EC, 2000/14/EC, 2014/30/EU, EN 500-1:2006 + A1:2009, EN 500-4:2011, EN ISO 13766-1:2018, EN ISO 13766-2:2018

Person responsible for technical documents

Wacker Neuson Produktion GmbH & Co. KG, Wackerstraße 6, D-85084 Reichertshofen

Reichertshofen, 06.12.2019

Helmut Bauer
Managing Director



EC Declaration of Conformity

Manufacturer

Wacker Neuson Produktion GmbH & Co. KG, Wackerstraße 6, D-85084 Reichertshofen
This declaration of conformity is issued under the sole responsibility of the manufacturer.

Product	VP2050
Product type	Vibratory plate
Function of product	Soil compaction
Material number	5100029050, 5100029051, 5100029052, 5100029053
Net installed power	3,6 kW
Measured sound power level	103 dB(A)
Guaranteed sound power level	108 dB(A)

Conformity assessment procedure

2000/14/EC, Annex VIII

Notified body

TÜV Rheinland LGA Products GmbH, Tillystr. 2, D-90431 Nürnberg (NB 0197)

Guidelines and standards

We hereby declare that this product complies with the relevant provisions and requirements of the following directives and standards:

2006/42/EC, 2000/14/EC, 2014/30/EU, EN 500-1:2006 + A1:2009, EN 500-4:2011, EN ISO 13766-1:2018, EN ISO 13766-2:2018

Person responsible for technical documents

Wacker Neuson Produktion GmbH & Co. KG, Wackerstraße 6, D-85084 Reichertshofen

Reichertshofen, 06.12.2019

Helmut Bauer
Managing Director

2 Preface

2.1 Introduction

This operator's manual contains important information and procedures for the safe, proper and economical operation of this Wacker Neuson machine. Carefully reading, understanding and observing it helps to avoid dangers, reduce repair costs and downtimes and thus increase the availability and service life of the machine.

This operator's manual is not a manual for extensive maintenance or repair work. Such work must be carried out by Wacker Neuson Service or by technically trained personnel. The Wacker Neuson machine must be operated and maintained in accordance with the instructions in this operator's manual. Improper operation or maintenance can cause hazards.

Defective machine parts must be replaced immediately!

Wacker Neuson contact persons are always available to answer questions about operation or maintenance.

2.2 Storage location of the operator's manual

This operator's manual must be kept in the immediate vicinity of the machine and accessible to personnel at all times.

If this operator's manual is lost or you require a new copy, there are two ways of obtaining a replacement:

- You can download it from the Internet - <http://www.wackerneuson.com>
- Or you can contact your Wacker Neuson representative.

2.2.1 Understanding these instructions

This section helps to understand the operator's manual and the illustrations used therein.



Target group

Persons, working with this machine, must be regularly trained with regard to the dangers and risks occurring when using this machine.

This operator's manual is aimed at:

- Operating personnel:
 - These persons have been instructed in working with the machine and about possible dangers and risks arising due to improper behavior.
- Technically trained personnel:
 - These persons have a professional training as well as additional knowledge and experience. They are capable of assessing the tasks assigned to them and recognizing any possible risks and dangers.

Explanation of symbols

Symbol	Explanation
1., 2., 3...	Indicates an activity. The sequence of the steps must be observed.
⇒	Indicates a result or an intermediate result of an action.
✓	Indicates prerequisites that must be established for the activity.
•	Indicates a list, e.g. if several components are named one after the other.
-	Indicates a sub-list, e.g. if components consist of further components
	Identifies a position, usually a component or control element, in a graphic. The numbering may be sequential or in Roman numerals.
1; A	Indicates the naming of components in explanatory texts. It is identical with the adjacent positions in the illustrations.
 	Indicates a direction of movement or different positions for switches.
▶	Indicates the avoidance of hazards in warning notices.
[▶52]	Indicates a cross-reference in tables. Here e.g. reference to page 52

Explanation of symbols



Symbol for warning notices

This symbol is a warning symbol. It is used to alert you to potential hazards. The safety symbol is always followed by a signal word, which indicates the hazard. These warnings are to be observed in particular. This protects the operator and third parties from personal injury and damage to property.



Symbol for environmental information

This symbol indicates environmental information. It is used to warn of possible environmental hazards.



Symbol for information

This symbol indicates information. This information can include tips on operation, for example. It helps to better understand and use the machine.



Symbol for compliance with EC directives

The CE mark documents that the machine complies with the valid EC directives.

2.3 Accident prevention regulations

In addition to the notes and safety instructions in this operator's manual, the local accident prevention regulations and the national industrial safety regulations apply.

2.4 Wacker Neuson Contact

Depending on the country, the Wacker Neuson contact is a Wacker Neuson Service, a Wacker Neuson subsidiary or a Wacker Neuson dealer.

On the Internet at - <http://www.wackerneuson.com>.

2.5 Labeling on the machine

Type label data

The type label contains information that uniquely identifies this machine. This information is required for ordering spare parts and for technical queries.

Enter the data on the machine in the following table:

Designation	Your details
Group - Type	
Material number (Mat. no.)	
Machine version (version)	
Machine number (machine no.)	
Year of construction	

2.6 Use of the operator's manual

This operator's manual:

- must be regarded as an integral part of the machine and must be kept in a safe place throughout its service life.
- must be passed on to each subsequent owner or user of this machine.
- applies to various machine types from one product range. For this reason, some illustrations may differ from the appearance of the purchased machine. Variant-dependent components that are not included in the scope of delivery can also be described.

Wacker Neuson reserves the right to change the information in this operator's manual without notice.

It must be ensured that any changes or additions made by the manufacturer are immediately incorporated into this operator's manual.

The following will be described:

Group - Machine Type	Material number (Mat. no.)
VP1135A	5100029066
VP1135Aw	5100029065
VP1135Aw CN	5100039666
VP1340A	5100029061
VP1340Aw	5100029060
VP1340Aw CN	5100039665
VP1340Aw	5100029062
VP1550A	5100029057



Group - Machine Type	Material number (Mat. no.)
VP1550Aw	5100029056
VP2050A	5100029053
VP2050Aw	5100029052
VP2050Aw CN	5100039664
VP1135A US	5100029064
VP1135AW US	5100029063
VP1340A US	5100029059
VP1340AW US	5100029058
VP1550A US	5100029055
VP1550AW US	5100029054
VP2050A US	5100029051
VP2050AW US	5100029050

3 Usage

3.1 Designated use

Designated use also includes observing all notes and safety instructions in this operator's manual and observing the prescribed care and maintenance instructions.

The machine is used for:

- Compaction in earth and gravel construction.
- Compaction of mixed and granular soils.
- Compaction of asphalt.
- Shaking in cobblestones.

Any other use or use that goes beyond this is considered improper use. The manufacturer shall not be liable or liable for any damage resulting therefrom. The risk is borne solely by the operator.

3.2 Unintended use

The manufacturer is not liable for personal injury or damage to property resulting from unintended use. The following activities, among others, are not intended:

- Compaction of strongly cohesive soils.
- Compaction of frozen soils.
- Compaction of hard, non-compactable soils.
- Compaction of non-load-bearing soils.

4 Safety

4.1 Safety symbols and signal words

The following symbol identifies safety instructions. It is used for warning against potential personal risk or danger.



DANGER

DANGER identifies a situation causing death or serious injury if it is not avoided.

Consequences in case of non-observance.

- ▶ Avoidance of injury or death.



WARNING

WARNING identifies a situation that can cause death or serious injury if it is not avoided.

Consequences in case of non-observance.

- ▶ Avoidance of injury or death.



CAUTION

CAUTION identifies a situation that can cause injury if it is not avoided.

Consequences in case of non-observance.

- ▶ Avoidance of injury.



NOTICE

INFORMATION identifies a situation that causes damage if it is not observed.

Consequences in case of non-observance

- ▶ Avoidance of damage to property.

4.2 Principle

The machine has been designed and built in accordance with latest state-of-the-art standards and the recognized safety regulations. Nevertheless, improper use may result in danger to life and limb of the operator, third parties or damage to the machine and other material property.

Read and observe the notes and safety instructions in this operator's manual. Failure to follow these instructions may result in electric shock, fire and/or serious injury, and damage to the machine and/or other objects.

Keep safety instructions and information for the future.

4.3 Structural changes

Structural modifications may not be made without the written consent of the manufacturer. Unauthorized structural changes may result in hazards to the operator and/or third parties as well as damage to the machine.

The manufacturer's liability and warranty are also void in the event of unauthorized structural alterations.

In particular, a structural change shall be deemed to have occurred:

- When opening of the machine and permanent removal of components.
- Installation of spare parts that do not come from Wacker Neuson or are not equivalent in design and quality to the original parts.
- Attachment of accessories of any kind that do not originate from Wacker Neuson.

Spare parts or accessories from Wacker Neuson can be installed or removed safely. Further information is available on the Internet at - <http://www.wackerneuson.com>.

4.4 Responsibility of the operator

The operator is the person who operates this machine himself for commercial or economic purposes or who leaves it to a third party for use/application and bears the legal product responsibility for the protection of personnel or third parties during operation.

The operator must make the operator's manual accessible to the personnel at all times and ensure that the operator has read and understood the operator's manual.

The operator's manual must be kept ready to hand at the machine or at the place of use.

The operator must hand over the operator to any other operator or subsequent owner of the machine.

The country-specific regulations, standards and directives on accident prevention and environmental protection must also be observed. The operator's manual must be supplemented by further instructions for compliance with operational, official, national or generally applicable safety guidelines.



4.5 Obligations of the operator

- Know and implement applicable health and safety regulations.
- In a risk assessment, identify hazards arising from working conditions at the place of use.
- Create operating instructions for the operation of this machine.
- Regularly check whether the operating instructions correspond to the current status of the regulations.
- Clearly regulate and define responsibilities for installation, operation, troubleshooting, maintenance and cleaning.
- Train personnel at regular intervals and inform them about possible dangers.
- Refresh instruction at regular intervals.
- Keep records of the training received and make them available to the competent authority on request.
- Provide personnel with the necessary protective equipment.

4.6 Qualification of staff

This machine may only be put into operation and operated by trained personnel.

In the event of misuse, abuse or operation by untrained personnel, there is a danger to the health of the operators and/or third parties, as well as damage or total failure of the machine.

In addition, the following requirements apply to the operator:

- Physical and mental suitability.
- Minimum age 18 years.
- No influence on reactivity by drugs, alcohol or medication.
- Familiarity with the safety instructions in this operator's manual.
- Familiarity with the intended use of this machine.
- Instructed in the independent operation of the machine.

4.7 Residual hazards

Residual hazards are special hazards when handling machines that cannot be eliminated despite their safety-conscious design.

These residual hazards are not obviously identifiable and may be the source of a potential injury or health hazard.

If unforeseeable residual hazards occur, the machine must be stopped immediately and the responsible supervisor informed. The latter makes further decisions and takes all necessary steps to eliminate the danger that arises.

If necessary, the manufacturer must be informed.

4.8 General safety instructions

The safety instructions in this chapter contain the "General safety instructions", which must be listed in the operator's manual in accordance with the applicable standards. It may contain instructions which are not relevant for this machine.

4.8.1 Workplace

- Before starting work, familiarize yourself with the working environment, e.g. load-bearing capacity of the floor or obstacles in the environment.
- Secure work area to public transport area.
- Necessary protection of walls and ceilings, e.g. in trenches.
- Keep unauthorized persons and children away when working with this machine. Distraction may result in loss of control of the machine, work must be carried out carefully.
- Always secure the machine against tipping, rolling, slipping and falling. Risk of injury!
- Keep work area tidy. Disorder or unlit work areas can lead to accidents.
- Observe the changing ground conditions, especially on uneven and soft ground or on slopes. Secure the machine against slipping!
- When working near pits, ditches or plateaus, exercise caution! The load-bearing capacity of the ground must safely carry the weight of the machine and the operator.

4.8.2 Personal safety

- Working under the influence of drugs, alcohol or medication can lead to serious injuries.
- Suitable protective equipment must be worn for all work. Personal protective equipment considerably reduces the risk of injury.
- Keep wide or loose clothing, protective gloves, jewellery and long hair away from moving machine parts. Danger of being drawn in!
- Always ensure that you are standing in a stable position, always stand with both feet on the ground.
- During prolonged work with this machine, vibration-related long-term damage cannot be completely excluded. Vibration load, [see Technical data on page 42](#).
- Ensure that there are no other persons in the danger zone!

Personal protective equipment



WARNING

Risk of hearing damage if the country-specific noise limit is exceeded!

Working with the machine without hearing protection can lead to hearing damage in the long-term.

- ▶ Wear ear protectors.
- ▶ Work attentively and cautiously when using hearing protection.



4.8.3 Handling and use

- Handle machines with care. Do not operate machines whose components or control elements are defective. Have defective components or control elements replaced immediately. Machines with defective components or control elements entail a high risk of injury!
- Do not lock, manipulate or alter the machine operating elements in an inadmissible manner.
- Secure unused machines against unauthorized commissioning. The machine may only be operated by authorized personnel.
- Handle machine with care. Have defective parts replaced immediately before this machine is commissioned. Defective machines entail a high risk of injury.
- Use the machine, accessories, tools etc. in accordance with these instructions.
- After operation, store the machine in a locked, clean, frost-protected, and dry location that is inaccessible to other persons and children.

4.9 Specific safety instructions for vibration plates

External influences

Do not operate the machine under the following external influences:

- In potentially explosive atmospheres. Explosion hazard!
- In case of heavy rain on inclined surfaces. Danger of slipping!
- If methane gas escapes from the ground in the vicinity of oil fields. Explosion hazard!
- In dry, highly flammable vegetation. Fire hazard!
- In the vicinity of open flames. Fire hazard!

Operational safety

- When operating the machine, make sure that no gas, water or electrical lines or pipes are damaged.
- Exercise the utmost degree of caution near abysses or slopes. Danger of falling!
- Do not leave the designated operating position when the machine is in operation.
- In trenches and pits, pay maximum attention to side walls so that they remain stable and do not collapse due to vibration. Risk of spillage!
- Never let the machine run unattended. Risk of injury!
- Keep work area clear and keep unauthorized persons away. Risk of injury!
- Operators of this machine must ensure that persons staying in the work area maintain a minimum distance of 2 metres from the running machine.
- When operating the machine on inclined surfaces, always approach gradients from below and always stand above the machine on the slope. The machine could slip or tip over.

Safety distances

Compaction work in the vicinity of buildings can lead to building damage. Therefore, any possible effects and vibrations on surrounding buildings must be checked in advance.

The relevant regulations and codes of practice for measuring, assessing and reducing vibration immissions must be observed, in particular DIN 4150-3.

The manufacturer shall not be liable for any damage to buildings.

4.10 Safety features

Safety features protect the operator of this machine from being exposed to the existing hazards. These are barriers (guards) or other technical measures. The source of danger is switched off or the danger is reduced in certain situations.



WARNING

Hot exhaust!

Contact may cause burns.

- ▶ Only operate the machine if the safety features are correctly fitted.
- ▶ Do not change or remove safety devices.



1 V-belt guard



4.11 Maintenance

- This machine must not be serviced, repaired, adjusted or cleaned when switched on.
- Observe maintenance intervals.
- Observe maintenance plan. Any work not listed must be carried out by the Wacker Neuson representative.
- After any maintenance or repair, the safety devices must be reattached to this machine.
- Always replace worn or damaged machine parts immediately. Use only spare parts from Wacker Neuson.
- Keep the machine clean.
- Replace any missing, damaged or illegible safety labels immediately. Safety labels contain important information to protect the operator.
- Maintenance work must be carried out in a clean and dry environment (e.g. workshop).

4.11.1 Service

- Only have the machine repaired or serviced by technically trained personnel.
- Only use original spare parts and accessories. This ensures the operational safety of the machine.

Threaded fittings

All threaded fittings must comply with the specified specifications and be firmly bolted together. Observe the tightening torques! Screws and nuts must not be damaged, bent or deformed.

Particular attention should be paid to the following:

- Self-locking nuts and micro-encapsulated screws must not be reused after loosening. The fastening effect is lost.
- Threaded fittings with adhesive protection/liquid adhesives (e.g. Loctite) must be cleaned after loosening and provided with new adhesive.



Information

Observe the instructions of the liquid adhesive manufacturer.

4.11.2 Vehicle fluids

- Always wear protective goggles and gloves when handling vehicle fluids. Seek medical advice immediately if, for example, hydraulic oil, fuel, oil or coolant gets into the eyes.
- Avoid direct skin contact with vehicle fluids. Wash skin immediately with soap and water.
- Do not eat or drink while working with vehicle fluids.
- Contaminated vehicle fluid (e.g. with dirt, water) can lead to premature wear or failure of the machine.
- Dispose of discharged or spilled vehicle fuel in accordance with applicable environmental regulations.
- If vehicle fluids leak from the machine, stop operating the machine and have it repaired immediately by a Wacker Neuson contact.

4.11.3 Combustion engine

- Before starting work, check the engine for leaks and cracks in the fuel line, tank and filler cap.
- Do not start the defective motor. Replace damaged parts immediately.
- The preset engine speed must not be adjusted. This could lead to engine damage.
- Ensure that the exhaust system of the engine is free of waste. Fire hazard!
- Before refueling, switch off the engine and let it cool down.
- Use the correct type of fuel. Observe the prescribed mixing ratios.
- Use clean filling aids for refueling. Do not spill fuel, wipe up spilled fuel immediately.
- Do not start the engine near spilled fuel. Explosion hazard!
- When operating in partially enclosed rooms, sufficient ventilation must be provided. Do not inhale exhaust gas. Danger of poisoning!
- The engine surface and exhaust system can become very hot after only a short time. Risk of burns!
- Do not use jump start sprays. These can cause misfiring and engine damage. Fire hazard!

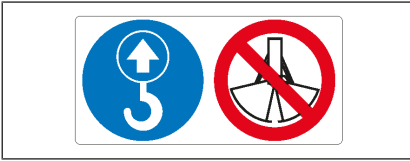

Risk of injury from falling machine

- Only lift at the lifting point.
- No lifting with an excavator bucket.

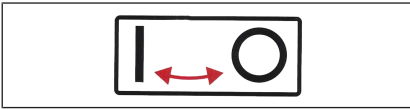

On/Of switch.

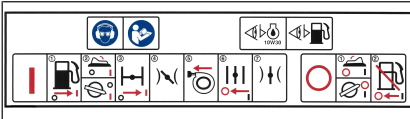

Use hearing protection and eye protection.

Read the operator's manual.

- Check oil and fuel levels.
- Start / stop brief instructions.

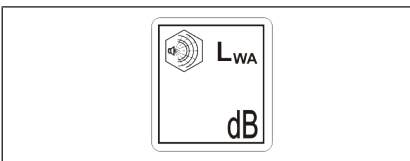

Guaranteed sound power level.

5.3 Components

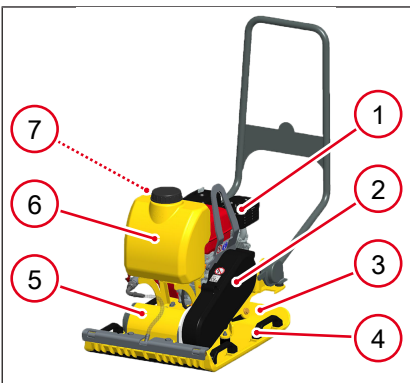

- 1 Drive motor
- 2 V-belt guard
- 3 Base plate
- 4 Handle (depending on variant)
- 5 Exciter
- 6 Water tank
- 7 Type label

5.4 Control elements

Always keep the displays and controls of the machine dry, clean and free of oil and grease.

Do not lock, manipulate or alter the machine operating elements in an inadmissible manner.



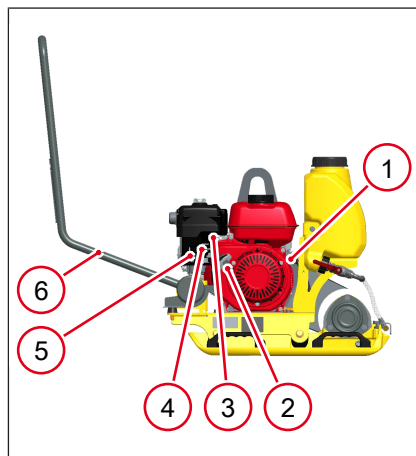

- 1 Engine switch
- 2 Handle reversing starter
- 3 Throttle lever
- 4 Choke lever
- 5 Fuel cock
- 6 Guide bracket

6 Transportation

6.1 Safety instructions for transport



WARNING

Danger of falling!

The falling machine can cause serious injuries, e.g. by crushing.

- ▶ Only use suitable and tested lifting gear and slings (safety hooks) with sufficient lifting capacity.
- ▶ Only lift the machine by the central suspension.
- ▶ Secure the machine safely to the lifting gear.
- ▶ Do not lift the machine by the guide bracket.
- ▶ Leave the danger area when lifting, do not stand under suspended loads.



WARNING

Fire hazard due to fuel!

Leaking fuel can catch fire and cause severe burns.

- ▶ Empty the fuel tank before transport.
- ▶ Lift the machine upright and transport it.

6

6.2 Prerequisites and preparations

- Switch off the machine and let it cool down.
- Only use suitable lifting gear with a minimum load capacity of 150 kg.

6.3 Lifting the machine

- ✓ To ensure safe lifting, appoint a competent instructor.
- ✓ The transport vehicle must have a sufficient bearing load and a suitable loading surface.
- ✓ Only use certified lifting and fastening gear.

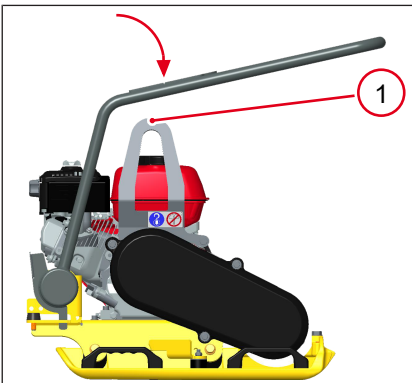

1. Fold down the guide bracket when lifting and transporting.
2. Attach suitable sling to central suspension **1**.
3. Load the machine into or onto the transport vehicle.

6.4 Lashing the machine



NOTICE

Use anti-slip mats to secure the load.

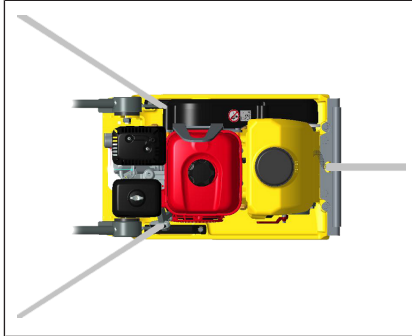

Only use the lashing points provided for this purpose to secure the machine.

- Tie down the machine as shown.
 - ⇒ The machine is secured against unrolling, slipping and tipping over.

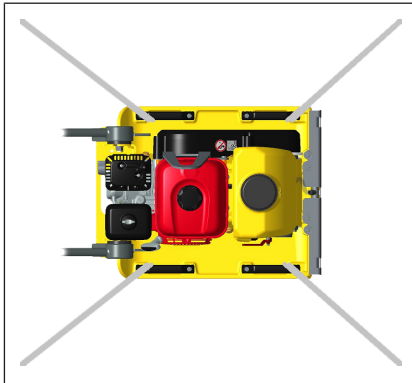

7 Commissioning

7.1 Tests before commissioning



Information

Further information and detailed descriptions, [see Maintenance on page 31](#).

Perform the following checks:

- Check machine and components for damage.
 - Do not put the damaged machine into operation. Damages and defects must be repaired immediately.
- Check fuel level.
- Check fuel lines for leaks.
- Check air filter.
- Check engine oil level.
- Check reversing starter.

7.2 Safety instructions for operation



WARNING

Tipping hazard due to slipping or overturning machine!

At least 2/3 of the machine must be on a stable surface near edges.

- ▶ Take the machine out of operation and lift it back onto a stable surface.

Operation on inclined surfaces



NOTICE

Technical damage due to failure of engine lubrication!

- ▶ Do not exceed the maximum permissible inclination, see [see Technical data on page 42](#).

- Only approach gradients from below.

Ground conditions

The maximum dumping height depends on several factors of the ground conditions. An exact specification of this value is not possible.

- Determine the maximum fill height by compaction tests or soil samples.

Shaking in cobblestones

- To avoid damage to the machine or compaction material, use a sliding device, [see Accessories on page 41](#).

Compaction of asphalt

- To avoid cracking and sticking to the asphalt, use water tank with sprinkler system, [see Accessories on page 41](#).

7.3 Putting into operation



WARNING

Danger of burns due to starting aid sprays!

Starting aid sprays can ignite and cause severe burns.

- ▶ Do not use any starting aid sprays.

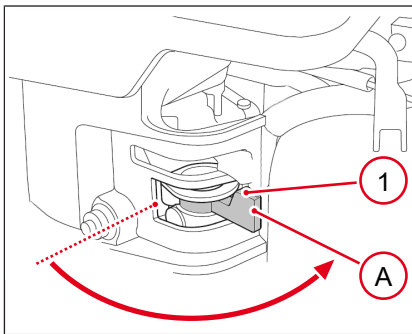

1. Move the fuel cock **1** into position **A**.

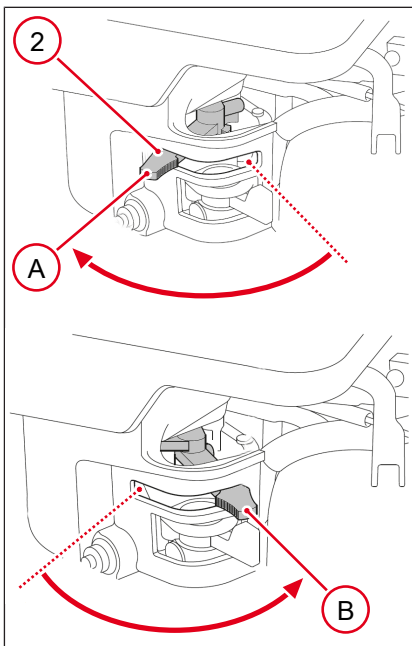

2. Move choke lever **2** to position **A** when the engine is cold.
3. Move the choke lever to position **B** when the engine is warm.

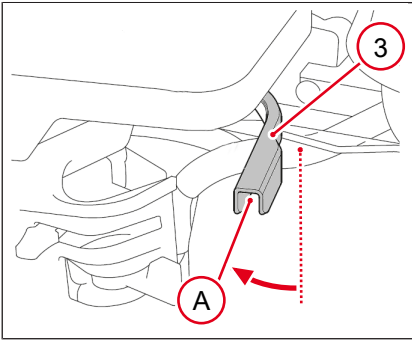

4. Move the throttle lever **3** into position **A**.

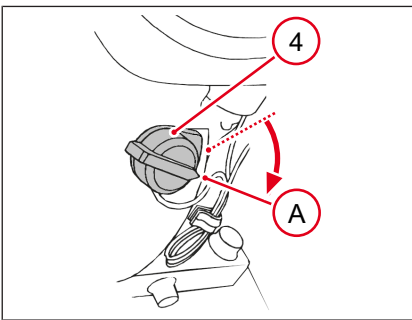

5. Move the engine switch **4** into position **A**.

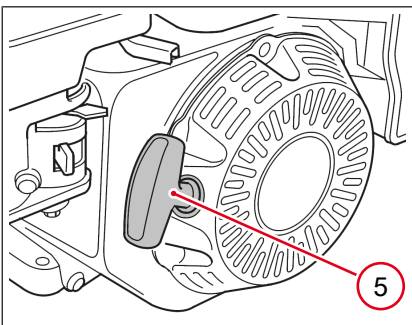

6. Pull the starting handle **5**.
⇒ Pull the starting handle slightly until resistance is felt, then pull it strongly. Slowly return the starting handle.

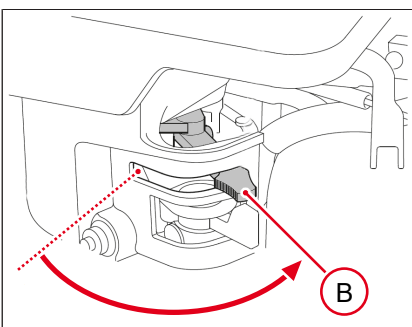

7. Move choke lever to position **A** for starting, move choke lever back to position **B** while the engine is warm.
⇒ Engine runs.

8 Operation

8.1 Operating the machine

The operator's designated location is behind the machine.
Guide and steer the machine by the guide handle.

8.2 Taking the machine out of operation

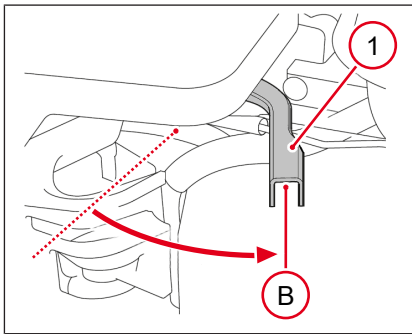

1. Move the throttle lever **1** to position **B**.

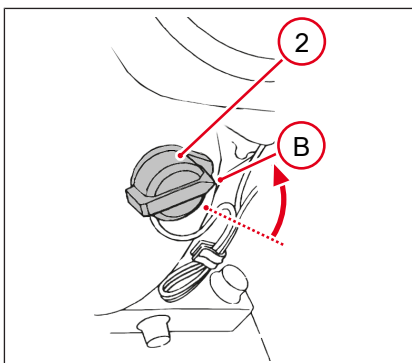

2. Move the engine switch **2** into position **B**.

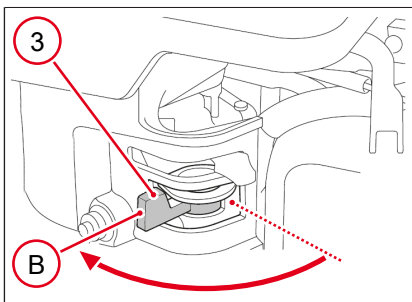

3. Move the fuel cock **3** into position **B**.
⇒ Let the machine and engine to cool down.

9 Maintenance

9.1 Safety instructions for maintenance



WARNING

Improper handling may result in injury or serious material damage.

- ▶ Please read and follow all safety instructions in this operator's manual.



WARNING

Danger of poisoning from exhaust fumes!

Exhaust fumes contain poisonous carbon monoxide, which can lead to unconsciousness or to death.

- ▶ Only perform maintenance work with the engine switched off and the machine decommissioned.



WARNING

Risk of injury from uncontrolled machine starts and moving parts.

- ▶ Only perform maintenance work with the engine switched off and the machine decommissioned.



WARNING

Fire and explosion hazard due to fuel and fuel vapors!

Fuel and fuel vapors can ignite or catch fire and cause serious burns.

- ▶ Do not smoke.
- ▶ Do not refuel near open fire.
- ▶ Switch off the engine and allow it to cool before refueling.



WARNING

Risk of fire and explosion when using flammable cleaning agents!

- ▶ Do not clean the machine and components with gasoline or other solvents.



WARNING

Burn hazard due to hot engine oil!

Splashes of hot oil can cause burns to the skin.

- ▶ Switch off the engine and let it cool down.
- ▶ Wear protective gloves.

⚠ WARNING

Risk of injury due to missing or non-functioning safety devices.

- ▶ Only operate the machine if the safety devices are correctly installed and functioning.
- ▶ Do not change or remove safety devices.

⚠ CAUTION

Health risk from fuel, lubricants and coolants!

- ▶ Do not inhale vapors.
- ▶ Avoid skin and eye contact.

NOTICE

If the engine is operated without an air filter, there is a risk of faster engine wear!

- ▶ Do not operate the engine without an air filter or air filter cover.

Environment

Soil contamination due to oil leaking or overflowing.

- ▶ Line work surface with impermeable foil.
- ▶ Use collecting container for used oil.
- ▶ Dispose of used oil in an environmentally friendly manner in accordance with statutory regulations.

Environment

Avoid damage to the environment!

- ▶ Clean the machine in a suitable place where the dirty waste water can be collected in an environmentally friendly manner.
- ▶ Collect contaminated water and dispose of it in an environmentally friendly manner.

9.2 Maintenance plan

NOTICE

Danger of engine damage!

- ▶ When commissioning new machines, an oil change must be carried out once after 20 operating hours.

Maintenance work	daily	weekl y	month ly	100 h	125 h	250 h	300 h	500 h
Clean the machine. • Visual check for completeness. • Visual check for damage.	•							
Check engine oil fill level.	•							
Check air filter intake area.	•							
Check screw connections.	•							
Clean fuel filter.	•							
Clean and check air filter.			•					
Check the exciter oil level.			•					
Check V-belt tension.			•					
Clean the deposit cup.				•				
Change engine oil.				•				
Check spark plugs.				•				
Check rubber buffer .*					•			
Replace exciter oil. *						•		
Check valve clearance.*							•	
Replace the fuel filter.								•
* Have this work carried out by a service partner.								

9.3 Maintenance work

Carrying out preparations

1. Place the machine on a level surface.
2. Decommissioning the machine.
3. Let the machine cool down.

9.3.1 Cleaning the machine

Observe the following when cleaning the machine with a high-pressure cleaner:

1. Do not aim high-pressure cleaner directly at air intake area and electrical components.
2. Do not hold the high-pressure cleaner too close to the machine in order to avoid damage to labels and sensitive components.

Visual check after cleaning:

1. Check cables, hoses and lines for leaks and chafe marks.
2. Check screw connections.
 - ⇒ Replace damaged components.
3. Check all safety, warning and operating instructions for completeness.
 - ⇒ Replace missing or damaged labels and signs immediately.

9.3.2 Checking and topping up the fuel level

1. Remove dirt.
2. Open tank lid.
3. Check the fuel level.
 - ⇒ Max. fuel level to lower edge of filler neck.
4. Refuel if necessary, *see Technical data on page 42*.
5. Close tank cap tightly.

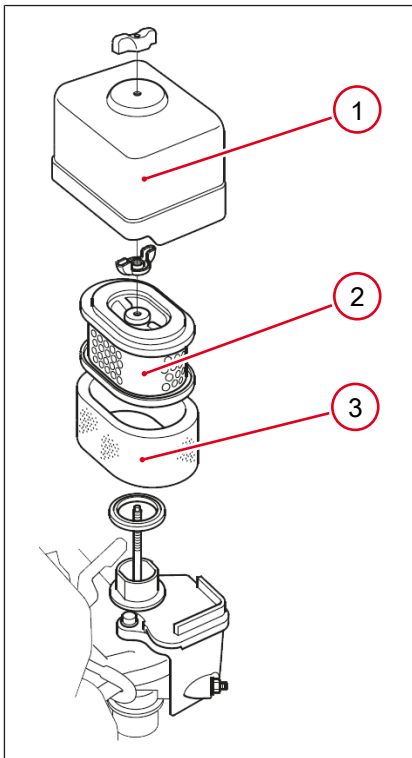
9.3.3 Cleaning and checking the air filter

1. Remove air filter lid **1**.
2. Remove and separate the air filter inserts.
 - ⇒ Paper filter insert **2** and foam filter insert **3**
3. Check both air filter inserts for cracks and holes, replace if damaged.

Cleaning the paper filter insert

1. Knock out filter insert on hard surface.
2. Blow with compressed air from the inside through the filter insert.
 - ⇒ Do not brush out, this will force dirt into the fibers.
 - ⇒ Replace if heavily soiled.

Cleaning the foam filter insert

1. Wash the filter insert in soapy water.
2. Rinse thoroughly with water.
3. Leave to dry.
4. Immerse in new engine oil, *see Technical data on page 42*.
5. Press out the filter insert.
 - ⇒ Excess engine oil will smoke when the engine is started.

9.3.4 Checking and topping up engine oil level



NOTICE

Danger of engine damage!

- ▶ Only change the oil when the engine is at operating temperature.
- ▶ Only use engine oil with the correct specification, *see Technical data on page 42.*

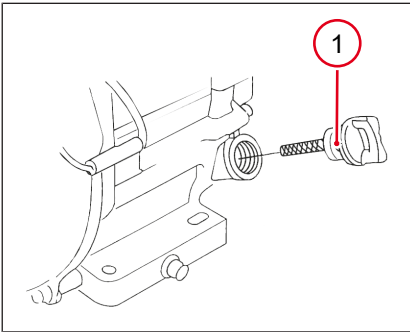

1. Remove dirt.
2. The machine must be horizontal.
3. Unscrew engine oil dipstick 1.
4. Wipe the engine oil dipstick with clean and fiber-free rags.
5. Tighten the engine oil dipstick again.
6. Unscrew the engine oil dipstick again.

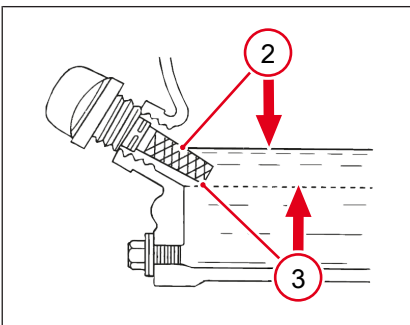

7. Check engine oil fill level.
 - ⇒ If the engine oil level is at the lower fill level limit 3, top up engine oil if necessary, *see Technical data on page 42.*
 - ⇒ Fill engine oil to the upper fill level limit 2, do not overfill.
- Tighten the engine oil dipstick again.

9.3.5 Replacing engine oil

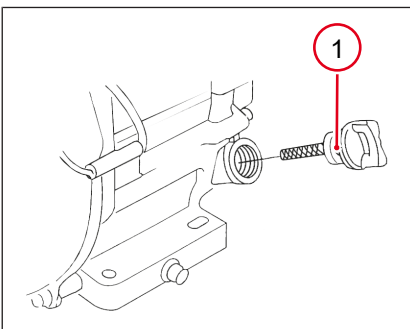

1. Remove dirt.
2. Provide a suitable container for draining the used oil.
3. Unscrew engine oil dipstick 1.

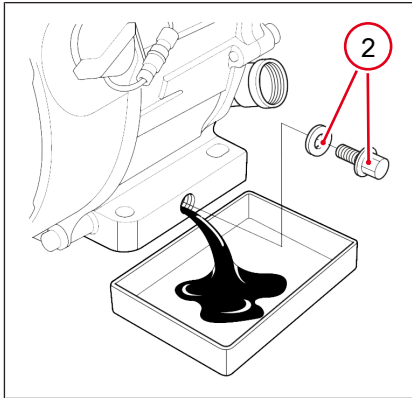

4. Unscrew the engine oil drain plug with sealing ring **2**.
5. Allow the used oil to drain completely.
6. Tighten the engine oil drain plug with new sealing ring, tightening torque 18 Nm.
7. Place the machine in a horizontal position.
8. Fill in new engine oil, [see Checking and topping up engine oil level on page 35](#).
9. Tighten the engine oil dipstick again.

9.3.6 Cleaning the deposit cup

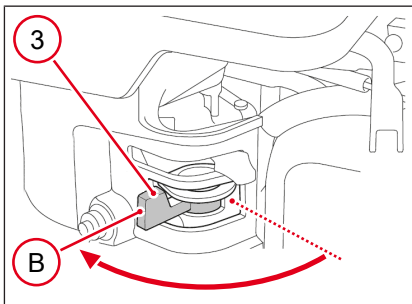

1. Move the fuel cock **3** into position **B**.

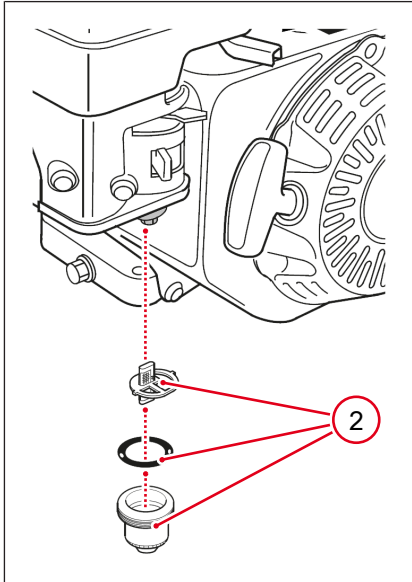

2. Remove deposit cup, filter and O-ring **2**.
3. Clean and dry deposit cup and filter.
4. Replace the O-ring, filter and sedimentation cup.

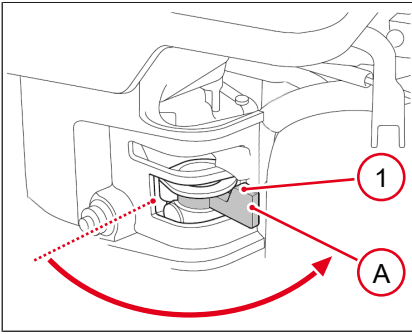

5. Move the fuel cock **1** into position **A**.
6. Check fuel system for leaks.

9.3.7 Checking spark plug



NOTICE

Danger of engine damage!

An incorrect spark plug can cause engine damage, [see Technical data on page 42](#).

- ▶ Correct electrode spacing.
- ▶ Free of deposits.

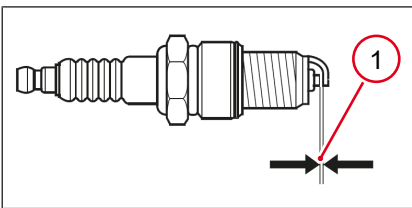

1. Pull out spark plug connector.
2. Remove dirt from the spark plug area.
3. Unscrew spark plug and check.
4. Replace if damaged or heavily soiled.
5. Measure electrode spacing **1**, [see Technical data on page 42](#).
⇒ Correct the electrode spacing by carefully bending it.
6. Tighten the spark plug again, tightening torque 18 Nm.
7. Plug the spark plug connector onto the spark plug.

9.3.8 Tighten and replace exciter V-belt

Tighten the V-belt

1. Remove the V-belt guard.
2. Unscrew the nuts of the motor V-belt pulley.
3. Remove outer V-belt pulley half.
4. Remove intermediate pulleys (as a rule, removing one pulley is sufficient).
5. Align and secure the removed intermediate pulleys and the outer V-belt pulley half.



Information

When tightening the nuts, turn the V-belt pulley to avoid jamming the V-belt.

1. Tighten the nuts, tightening torque 25 Nm.
2. Fit the V-belt guard, tightening torque 15 Nm.

10 Malfunctions

10.1 Troubleshooting



WARNING

Danger to life due to unauthorized troubleshooting!

- ▶ If faults occur on this machine which are not described in these instructions, contact the manufacturer.
- ▶ Do not rectify faults on your own.

Fault	Possible cause	Remedy
The engine cannot be started.	Engine switch off.	Engine switch on.
	Throttle lever in stop or idle position.	Throttle lever on.
	Not enough fuel.	Refill with fuel. Check fuel filter and fuel lines.
	Incorrect valve clearance.	Check valve clearance, have it adjusted if necessary.*
	Valves worn.	Have the machine repaired.*
	Cylinder and/or piston ring worn.	
	Spark plugs worn.	
	Engine oil level too low.	Add engine oil.
No vibration when the engine is running.	V-belt worn.	Change V-belt.
	Clutch linings worn out.	Have the clutch linings replaced.*
* Have this work carried out by a service partner.		

11 Decommissioning

11.1 Temporary decommissioning



Information

Further information and detailed descriptions, [see Maintenance on page 31](#).

If the machine is stationary for more than 1 month, perform the following measures:

Entire machine.	<ul style="list-style-type: none"> • Clean thoroughly. • Check for leaks, rectify any defects if necessary. • Store dust-free and dry.
Fuel tank.	Plastic tank: <ul style="list-style-type: none"> • Drain fuel completely. Metal tank: <ul style="list-style-type: none"> • Refill with fuel.
Engine.	<ul style="list-style-type: none"> • Check engine oil level, top up engine oil, if necessary. • Check and clean air filter. • Clean fuel filter.
Corrosion-prone components such as safety bolt, spindle and throttle cable.	Oil and grease.

If the machine is shut down for more than 6 months, contact a service partner.

11.2 Final shutdown

If the machine is no longer in use and is shut down for good, all operating fluids must be drained.

Have the machine professionally dismantled and disposed of by a state-approved recycling company.

Professional disposal of this machine avoids negative effects on human health and the environment, helps with the targeted treatment of pollutants and makes it possible to recycle valuable raw materials.

12 Accessories

12.1 Accessories



CAUTION

Risk of injury and possible machine damage!

Using non-original accessories or spare parts can lead to injuries or machine damage.

- ▶ Use only original parts.
- ▶ In case of disregard, no liability will be accepted.



CAUTION

Stability of the machine with wheel set!

Tipping over or rolling away of the machine can lead to injuries or material damage.

- ▶ Park the machine safely.
- ▶ Secure the wheel set against rolling away or fold it up.



Wheel set

Wheel set for easier transport on the construction site.

Water tank

Water tank with continuously adjustable sprinkler system, [see Safety instructions for operation on page 28](#).

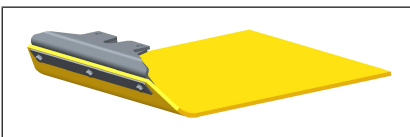

Slide mechanism

Surface protection, [see Safety instructions for operation on page 27](#).

13 Technical data

13.1 General instructions



Information

For system technical reasons, empty columns can be displayed in the technical data, and numbers and letters that written in superscript or subscript may be displayed incorrectly, e.g:

- ▶ Sound power level LWA instead of L_{WA}
- ▶ Sound pressure level LpA instead of L_{pA}
- ▶ Vibration total value ahv instead of a_{hv}
- ▶ Carbon dioxide CO₂ instead of CO₂
- ▶ Unit m/s2 instead of m/s^2

13.2 Noise and vibration data

The noise and vibration data listed have been determined in accordance with the following guidelines for the typical machine operating conditions / special test conditions and using harmonized standards:

- Machinery Directive 2006/42/EC
- Noise Emission Directive 2000/14/EC

During operational use, values may differ depending on the prevailing operating conditions.

Sound pressure level at operator station

- L_{pA} was determined according to EN ISO 11201 and EN 500-4.

Guaranteed sound power level

- L_{WA} was determined according to EN ISO 3744 and EN ISO -4.

Weighted vibration total value hand-arm vibration

- a_{hv} was determined according to EN ISO 20643 and EN 500-4.

13.3 VP

Type	VP1135A	VP1135Aw
Material number machine	5100029066	5100029065
Material number engine	5100045994	5100045994
Centrifugal force [kN]	11	11
Vibrations [Hz]	98	98
Vibrations [1/min]	5880	5880
Area output* [m ² /h]	533	533
Flow [m/min]	25	25
Gradeability [%]	36,4	36,4
Length (drawbar in working position) [mm]	958	958

Type	VP1135A	VP1135Aw
Width [mm]	355	355
Height [mm]	918	918
Underclearance [mm]	467	566
Operating weight [kg]	61	69
Nominal power** [kW]	2,6	2,6
Rated speed [1/min]	3600	3600
Exciter oil quantity [l]	-	-
Exciter oil type	-	-
Operating temperature range [°C]	-15 - +45	-15 - +45
Storage temperature range [°C]	-15 - +40	-15 - +40
Sound pressure level at operator station LpA [dB(A)]	91	91
Sound power level LWA, measured [dB(A*)	100	100
Sound power level LWA guaranteed [dB(A)]	105	105
Vibration total value ahv [m/s ²]	4,7	4,5
Measurement uncertainty of the total vibration value ahv [m/s ²]	0,5	0,5
*Depends on the soil conditions.		
** Corresponds to the installed net power according to Directive 2000/14/EC.		

Type	VP1340A	VP1340Aw
Material number machine	5100029061	5100029060
Material number engine	5100045995	5100045995
Centrifugal force [kN]	13	13
Vibrations [Hz]	98	98
Vibrations [1/min]	5880	5880
Area output* [m ² /h]	600	600
Flow [m/min]	25	25
Gradeability [%]	36,4	36,4
Length (drawbar in working position) [mm]	1040	1040
Width [mm]	400	400
Height [mm]	937	937
Underclearance [mm]	549	580
Operating weight [kg]	81	93
Nominal power** [kW]	3,6	3,6
Rated speed [1/min]	3600	3600
Exciter oil quantity [l]	0,25	0,25
Exciter oil type	75W-90 API GL-4	75W-90 API GL-4
Operating temperature range [°C]	-15 - +45	-15 - +45
Storage temperature range [°C]	-15 - +40	-15 - +40
Sound pressure level at operator station LpA [dB(A)]	92	92
Sound power level LWA, measured [dB(A*)	100	100
Sound power level LWA guaranteed [dB(A)]	108	108

Type	VP1340A	VP1340Aw
Vibration total value ahv [m/s ²]	3,1	2,6
Measurement uncertainty of the total vibration value ahv [m/s ²]	0,5	0,5
*Depends on the soil conditions.		
** Corresponds to the installed net power according to Directive 2000/14/EC.		

Type	VP1340Aw	VP1550A
Material number machine	5100029062	5100029057
Material number engine	5100045995	5100045995
Centrifugal force [kN]	13	15
Vibrations [Hz]	98	98
Vibrations [1/min]	5880	5880
Area output* [m ² /h]	600	750
Flow [m/min]	25	25
Gradeability [%]	36,4	36,4
Length (drawbar in working position) [mm]	1040	1035
Width [mm]	400	503
Height [mm]	937	940
Underclearance [mm]	580	552
Operating weight [kg]	93	93
Nominal power** [kW]	3,6	3,6
Rated speed [1/min]	3600	3600
Exciter oil quantity [l]	0,25	0,25
Exciter oil type	75W-90 API GL-4	75W-90 API GL-4
Operating temperature range [°C]	-15 - +45	-15 - +40
Storage temperature range [°C]	-15 - +40	-15 - +40
Sound pressure level at operator station LpA [dB(A)]	92	91
Sound power level LWA, measured [dB(A)*]	100	101
Sound power level LWA guaranteed [dB(A)]	108	108
Vibration total value ahv [m/s ²]	2,6	3,1
Measurement uncertainty of the total vibration value ahv [m/s ²]	0,5	0,5
*Depends on the soil conditions.		
** Corresponds to the installed net power according to Directive 2000/14/EC.		

Type	VP1550Aw	VP2050A
Material number machine	5100029056	5100029053
Material number engine	5100045995	5100045995
Centrifugal force [kN]	15	20
Vibrations [Hz]	98	98
Vibrations [1/min]	5880	5880
Area output* [m ² /h]	750	750
Flow [m/min]	25	25

Type	VP1550Aw	VP2050A
Gradeability [%]	36,4	36,4
Length (drawbar in working position) [mm]	1035	1035
Width [mm]	503	503
Height [mm]	940	940
Underclearance [mm]	583	552
Operating weight [kg]	102	100
Nominal power** [kW]	3,6	3,6
Rated speed [1/min]	3600	3600
Exciter oil quantity [l]	0,25	0,25
Exciter oil type	75W-90 API GL-4	75W-90 API GL-4
Operating temperature range [°C]	-15 - +40	-15 - +40
Storage temperature range [°C]	-15 - +40	-15 - +40
Sound pressure level at operator station LpA [dB(A)]	91	94
Sound power level LWA, measured [dB(A*)	101	103
Sound power level LWA guaranteed [dB(A)]	108	108
Vibration total value ahv [m/s ²]	2,7	3,6
Measurement uncertainty of the total vibration value ahv [m/s ²]	0,5	0,5
*Depends on the soil conditions.		
** Corresponds to the installed net power according to Directive 2000/14/EC.		

Type	VP2050Aw	VP1550Aw
Material number machine	5100029052	5100051526
Material number engine	5100045995	5100045995
Centrifugal force [kN]	20	15
Vibrations [Hz]	98	98
Vibrations [1/min]	5880	5880
Area output* [m ² /h]	750	750
Flow [m/min]	25	25
Gradeability [%]	36,4	36,4
Length (drawbar in working position) [mm]	1035	1035
Width [mm]	503	503
Height [mm]	940	940
Underclearance [mm]	583	583
Operating weight [kg]	110	102
Nominal power** [kW]	3,6	3,6
Rated speed [1/min]	3600	3600
Exciter oil quantity [l]	0,25	0,25
Exciter oil type	75W-90 API GL-4	75W-90 API GL-4
Operating temperature range [°C]	-15 - +40	-15 - +40
Storage temperature range [°C]	-15 - +40	-15 - +40
Sound pressure level at operator station LpA [dB(A)]	94	91

13.4 Combustion engine

Type	VP2050Aw	VP1550Aw
Sound power level LWA, measured [dB(A)*	103	101
Sound power level LWA guaranteed [dB(A)]	108	108
Vibration total value ahv [m/s ²]	3,1	2.7
Measurement uncertainty of the total vibration value ahv [m/s ²]	0,5	0.5

*Depends on the soil conditions.

** Corresponds to the installed net power according to Directive 2000/14/EC.

13.4 Combustion engine

Engine manufacturer	Honda
Material number engine	5100045994
Engine type	GX 120
Combustion processes	four-stroke
Cooling	Air
Cylinder	1
Cubic capacity [cm ³]	118
Inclined position max. [°]	20
Fuel type	Gasoline
Fuel consumption [l/h]	1
Tank volume [l]	2,5
Oil specification	SAE 10W-30
Oil filling max. [l]	0,6
Output max. [kW]	2,6
RPM [1/min]	3600
Standard	SAE J1349
Exhaust-emission level	EU Stage V, US Phase 3
CO ₂ emission* [g/kWh]	976
Exhaust gas aftertreatment	-
Spark plug type	NGK BP-6 ES
Electrode gap [mm]	0,7 - 0,8

* Determined value of the CO₂ emission during engine certification without consideration of the applications on the machine.

Engine manufacturer	Honda
Material number engine	5100045995
Engine type	GX 160
Combustion processes	four-stroke
Cooling	Air
Cylinder	1
Cubic capacity [cm ³]	163
Inclined position max. [°]	20
Fuel type	Gasoline

Engine manufacturer	Honda
Fuel consumption [l/h]	0,8
Tank volume [l]	3,6
Oil specification	SAE 10W-30
Oil filling max. [l]	0,6
Output max. [kW]	3,6
RPM [1/min]	3600
Standard	SAE J1349
Exhaust-emission level	EU Stage V, US Phase 3
CO ₂ emission* [g/kWh]	757
Exhaust gas aftertreatment	-
Spark plug type	NGK BP-6 ES
Electrode gap [mm]	0,7 - 0,8
* Determined value of the CO ₂ emission during engine certification without consideration of the applications on the machine.	



**WACKER
NEUSON**
all it takes!

**Wacker Neuson Produktion GmbH &
Co. KG**

Wackerstraße 6
D-85084 Reichertshofen

Tel.: +49 8453 340-0
EMail: service-LE@wackerneuson.com
www.wackerneuson.com

Material number: 5100056064

Language: [en]