



USER MANUAL



**Lifan Petrol 3000psi
Pressure Washer**

**Product Code:
DAN3000A**



Serial Number Range:

From:

To:

Year Of Manufacture:

***Please note, when ordering online via our website if the part number is not recognised,
please Email spares@hscgroupuk.co.uk or Telephone 0115 946 1988**

KEEP THIS BOOKLET FOR FUTURE REFERENCE

Nottingham: 0115 946 1988 • London: 0208 830 3333 ✉ Nottingham: sales@hscgroupuk.co.uk • London: sean@hscgroupuk.co.uk 🌐 www.hscgroupuk.co.uk

The Hire Supply Company Terms & Conditions Apply At All Time E&OE

PRESSURE WASHER

PROFESSIONAL POWER EQUIPMENT

OPERATION INSTRUCTION AND PARTS LIST MANUAL

For general direct drive gas pressure washer



Version: 2010-2



This manual contains:
IMPORTANT WARNINGS and **INSTRUCTIONS**. READ AND RETAIN FOR REFERENCE

⚠ WARNING: To reduce the risk of injury, the user must read and understand the operators manual before using this product.

SAVE THIS MANUAL FOR FUTURE REFERENCE

TABLE OF CONTENTS

<i>Introduction</i>	1
<i>Product Identification</i>	1
<i>Important Safety Instructions</i>	2-4
<i>Know Your Pressure Washer</i>	5
<i>Assembly</i>	6
<i>Before Use</i>	7-8
<i>Pressure Washer Location</i>	9
<i>Start Your Power Washer</i>	10
<i>Use The Nozzle Tips</i>	11
<i>Rinsing Pressure</i>	12
<i>Apply Chemical</i>	12
<i>Maintenance</i>	13-14
<i>Storage</i>	15
<i>Trouble Shooting Guide</i>	16-17
<i>Unit Exploded View And Parts List</i>	18
<i>Pump Exploded View and Parts List</i>	19

INTRODUCTION

Thank You for Purchasing our Professional Power Equipment Product

This instruction manual is intended for your benefit. Please read and follow the safety, installation, maintenance and troubleshooting steps described within to ensure your safety and satisfaction. The contents of this instruction manual are based upon the latest product information available at the time of publication. The manufacturer reserves the right to make product changes at any time without notice.

PRODUCT IDENTIFICATION

RECORD IDENTIFICATION NUMBERS

If you need to contact an Authorized Dealer for information on servicing, always provide the product model and identification numbers.

You will need to locate the model, revision and serial number for the machine and record the information in the places provided below. You will also need the model and serial number for the engine on your machine.

See the engine operators manual for the location of these numbers.

DATE OF PURCHASE:

DEALER NAME:

DEALER PHONE:

Product Identification Numbers

UNIT MODEL NAME:

ENGINE

MODEL:

SERIAL NUMBER:

PUMP

MODEL:

SERIAL NUMBER:

IMPORTANT SAFETY INSTRUCTIONS

This manual contains information that is important for you to know and understand. This information relates to protecting **YOUR SAFETY** and **PREVENTING EQUIPMENT PROBLEMS**. To help you recognize this information, we use the symbols below. Please read the manual and pay attention to these sections.

DANGER

DANGER indicates an imminently hazardous situation which, if not avoided, will result in death or serious injury.

CAUTION

CAUTION indicates a potentially hazardous situation which, if not avoided, may result in minor or moderate injury.

WARNING

WARNING indicates a potentially hazardous situation which, if not avoided, could result in death or serious injury.

CAUTION

CAUTION used without the safety alert symbol indicates a potentially hazardous situation which, if not avoided, may result in property damage.



DANGER--RISK OF EXPLOSION OR FIRE



- Fuel and its vapors are extremely flammable and explosive.
- Fire or explosion can cause severe burns or death.

- **ALWAYS** shut off engine and allow it to cool at least 2 minutes before adding fuel to the tank.
- **ALWAYS** use care in filling tank to avoid spilling fuel. Move pressure washer away from fueling area before starting engine.
- **ALWAYS** Keep maximum fuel level below top of tank to allow for expansion.
- **ALWAYS** operate and fuel equipment in well ventilated areas free from obstructions. Equip areas with fire extinguishers suitable for gasoline fires.
- **NEVER** operate pressure washer in an area containing dry brush or weeds.
- **ALWAYS** keep pressure washer a minimum of four feet away from surfaces (such as houses, automobiles, or live plants) that could be damaged from muffler exhaust heat.
- **ALWAYS** Store fuel in an OSHA approved container, in a secure location away from work area.
- **NEVER** spray flammable liquids



DANGER-- RISK TO BREATHING



- Running engine gives off carbon monoxide, an odorless, colorless, poison gas.
- Breathing carbon monoxide can cause nausea, fainting or death.
- Some chemicals or detergents may be harmful if inhaled or ingested, causing severe nausea, fainting or poisoning.

- **ALWAYS** Operate pressure washer in a well ventilated area. Avoid enclosed areas such as garages, basements, etc.
- **ALWAYS** Keep exhaust gas from entering a confined area through windows, doors, ventilation intakes, or other openings.
- **NEVER** operate unit in a location occupied by humans or animals.
- **ALWAYS** use the only fluids specifically recommended for high pressure washers.
- **ALWAYS** follow manufacturers recommendations, use a respirator or mask whenever there is a chance that vapors may be inhaled.
- **NEVER** use chlorine bleach or any other corrosive compound.



WARNING--RISK OF FALL HAZARD



- Use of pressure washer can create puddles and slippery surfaces.
- Kickback from spray gun can cause you to fall.

- Keep operating area clear of all persons, pets, and obstacles.
- Do not operate the product when fatigued or under the influence of alcohol or drugs. Stay alert at all times.
- Never defeat the safety features of this product.
- Do not operate machine with missing, broken, or unauthorized parts.
- Never leave wand unattended while unit is running.
- If engine does not start after two pulls, squeeze trigger of gun to relieve pump pressure. Pull starter cord slowly until resistance is felt. Then pull cord rapidly to avoid kickback and prevent hand or arm injury.
- Keep children away from the pressure washer at all times.
- Do not overreach or stand on an unstable support.
- The cleaning area should have a dequate slopes and drainage to reduce the possibility of a fall due to slippery surfaces.
- Be extremely careful if you must use the pressure washer from a ladder, scaffolding, or any other similar location.
- Firmly grasp spray gun with both hands when using high pressure spray to avoid injury when spray gun kicks back.



WARNING--RISK OF ELECTRICAL SHOCK



- Risk of electrocution.
- Contact with power source can cause electric shock or burn.

- Unplug any electrically operated product before attempting to clean it. Direct spray away from electric outlets and switches.
- NEVER spray near power source.



WARNING--RISK TO FLUID INJECTION



- The high pressure stream of water that this equipment produces can cut through skin and its underlying tissues, leading to serious injury and possible amputation. Spray gun traps high water pressure, even when engine is stopped and water is disconnected, which can cause injury.

- ALWAYS point spray gun in safe direction and squeeze trigger, to release high pressure, every time you stop engine.
- NEVER aim spray gun at people, animals, or plants.
- NEVER place hands in front of nozzle.
- Make sure hose and fittings are tightened and in good condition. Never hold onto the hose or fittings during operation.
- Do not allow hose to contact muffler.
- Never attach or remove wand or hose fittings while system is pressurized.
- Use only hose and high pressure accessories rated for pressure higher than your pressure washer's p.s.i.
- To relieve system pressure, shut off engine, turn off water supply, and pull gun trigger until water stops flowing.
- DO NOT allow CHILDREN to operate pressure washer.
- NEVER repair leaking connections with sealant of any kind. Replace o-ring or seal.
- NEVER connect high pressure hose to nozzle extension.
- Keep high pressure hose connected to pump and spray gun while system is pressurized.
- DO NOT secure spray gun in open position.
- DO NOT leave spray gun unattended while machine is running.
- NEVER use a spray gun which does not have a trigger lock or trigger guard in place and in working order.
- ALWAYS be certain spray gun, nozzles and accessories are correctly attached.



DANGER-- RISK OF CHEMICAL BURN



- Use of acids, toxic or corrosive chemicals, poisons, insecticides, or any kind of flammable solvent with this product could result in serious injury or death.

- Do not use acids, gasoline, kerosene, or any other flammable materials in this product. Use only household detergents, cleaners and degreasers recommended for use in pressure washers.
- Wear protective clothing to protect eyes and skin from contact with sprayed materials.
- Do not use chlorine bleach or any other corrosive compound



DANGER-- RISK OF HOT SURFACES



- Contact with hot surfaces, such as engines exhaust components, could result in serious burn.

- During operation, touch only the control surfaces of the pressure washer. Keep children away from the pressure washer at all times. They may not be able to recognize the hazards of this product.



DANGER-- RISK OF MOVING PARTS



- Starter and other rotating parts can entangle hands, hair, clothing, or accessories.

- NEVER operate pressure washer without protective housing or covers.
- DO NOT wear loose clothing, jewelry or anything that may be caught in the starter or other rotating parts.
- Tie up long hair and remove jewelry.



DANGER-- RISK OF EYE INJURY



- Spray can splash back or propel objects.

- Always wear safety goggles when using this equipment or in vicinity of where equipment is in use.
- Before starting the pressure washer, be sure you are wearing adequate safety goggles.
- NEVER substitute safety glasses for safety goggles.

KNOW YOUR PRESSURE WASHER

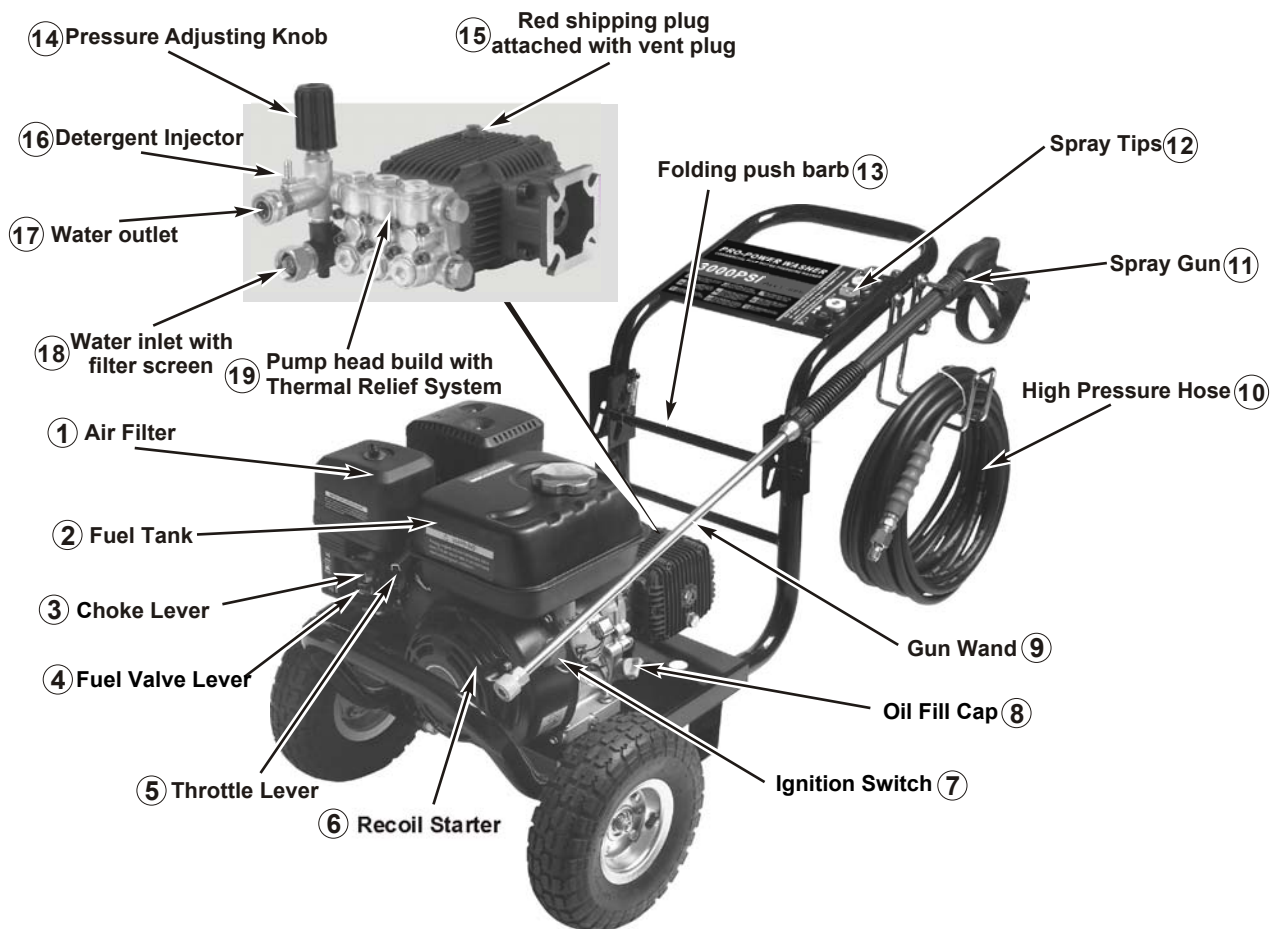

1. **Air Filter** -- Protects engine by filtering dust and debris out of intake air.
2. **Fuel Tank** -- Fill tank with regular unleaded fuel. Always leave room for fuel expansion.
3. **Choke Lever** -- Prepares a cold engine for starting.
4. **Fuel Valve** -- Used to turn fuel on and off to engine.
5. **Throttle Lever** -- Sets engine in starting mode for recoil starter.
6. **Recoil Starter** -- Use for starting the engine manually.
7. **Ignition Switch** -- Set this switch to "On" before using recoil starter. Set switch to "Off" to switch off engine.
8. **Oil Fill Cap** -- Fill engine with oil here.
9. **Gun wand with Quick Connect** -- To attach the spray tips on it.
10. **High Pressure Hose** -- Connect one end to the water pump and the other end to the spray gun.
11. **Spray Gun** -- Controls the application of water onto cleaning surface with trigger device. Includes safety latch.
12. **Spray Tips** -- 0/15/25/40 degree and soap nozzle for various high pressure cleaning applications.
13. **Folding push Barb** -- To push this barb to folding the frame.

14. **Pressure Adjusting Knob** -- To raising or reduce the pressure by turn the knob.
 15. **Red shipping plug attached with vent plug** -- The pump is ship with red shipping plug to prevent oil leaking during transportation. Replace with the attached vent plug before using.
 16. **Detergent Injector** -- Use to siphon detergent or other pressure washer chemicals into the low pressure stream.
 17. **Water outlet** -- To connect high pressure hose.
 18. **Water inlet with filterscreen** -- Connect garden hose here, and always have the filter screen present in it.
 19. **Pump Head Build with Thermal Relief System** -- Cycles water through pump when water reaches 125--155°F. Warm water will discharge from pump onto ground. This system prevents internal pump damage.
- PSI:** Pounds per square inch -- common unit measure used for water pressure, air pressure, hydraulic pressure and pounds of force.
- GPM:** Gallons per minute (liters per minute [metric]) -- common unit measure used for flow rate of water.
- Bypass Mode:** In bypass mode, high pressure pump recirculates water because spray gun trigger is not pulled.

ASSEMBLY

Your pressure washer requires some assembly and is ready for use after it has been properly serviced with the recommended oil and fuel. Tool need open-end wrench 10mm, 14mm, 17mm.

1. Unpack Pressure Washer.

- 1.1 Set carton on a rigid, flat surface. Remove all loose parts and packing. Leave pressure washer in carton.

WARNING Unit is heavy. Do not attempt to lift and remove the pressure washer unit from the carton.



- 1.2 Using a box cutter, open carton completely by cutting the four corners allowing the sides to lay flat. Leave pressure washer on carton while installing wheel, leg rubber bumpers.

2. Assembly the Wheel

- 2.1 Fit the axles into the axle ports as shown, secure with the nut, spring washer and washer
- 2.2 Fit the wheels to the axles and secure with the nut and washer.

NOTE: Do not over tighten the nuts, the wheels must be able to rotate freely.

3. Assembly the Rubber Feet.

- 3.1 Fit the rubber feet to the legs as shown.

4. Assembly the Gun/Hose Hook

- 4.1 Fit the hook into the position shown and secure using the washers and nuts on the bracket

5.0 Preparing Pressure Pump

The pressure pump has a shipping plug inserted into the opening for the pump breather plug.

WARNING Failure to remove shipping plug and replace it with the dipstick/oil plug will damage pressure pump. Failure to add pump breather plug could void warranty

- 5.1 Using an 17mm open-end wrench or socket wrench, remove shipping plug from pressure pump. Discard shipping plug.
- 5.2 Remove pump breather plug from parts bag and insert it into pressure pump.
- 5.3 Tighten pump breather plug securely by hand. Do not use openend wrench or socket wrench to tighten. Using a wrench to tighten pump breather plug could strip threads.
- 5.4 Use sight glass on end of pressure pump to ensure pump oil is at 1/2 of the sight glass level
- 5.5 Add oil to pressure pump if level is below indicator on oil gauge. Use 30-weight non-detergent oil.
- 5.6 We recommend the use high-quality detergent oils, if classified for service SF, SG, SH, SJ or higher. DO NOT use special additives. Outdoor temperatures determine the proper oil viscosity.
**Below 40 °F (4 °C) the use of SAE 30 will result in hard starting.
**Above 80 °F (27 °C) the use of 10W30 may cause increased oil consumption. Check oil level more frequently.

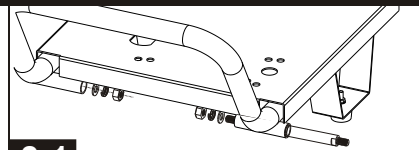

2.1

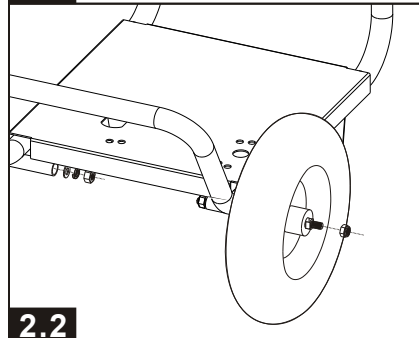

2.2

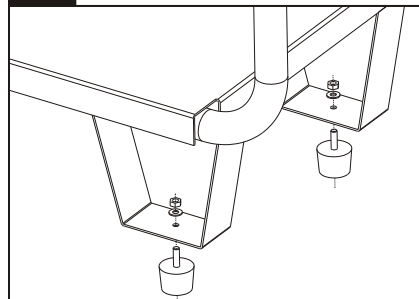

3.1

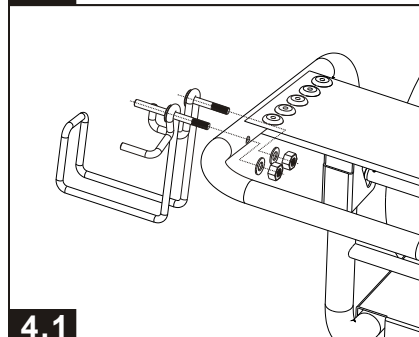

4.1

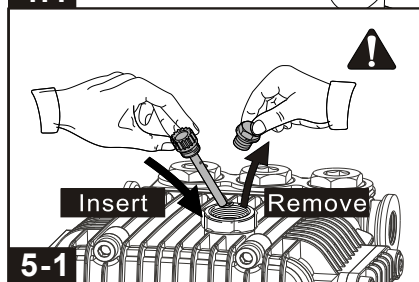

5-1

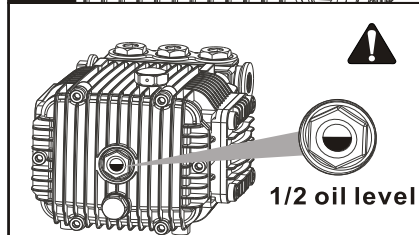

5-2

BEFORE USE

1. Add Engine Oil

- 1.1 Place pressure washer on a flat, level surface.
- 1.2 Clean area around oil fill and remove yellow oil fill cap.
- 1.3 Using oil funnel (optional), slowly pour contents of provided oil bottle into oil fill opening.
- 1.4 Replace oil fill cap and fully tighten.

NOTICE

Improper treatment of pressure washer can damage it and shorten its life.

DO NOT attempt to crank or start the engine before it has been properly serviced with the recommended oil. This may result in an engine failure.

2. Adding Fuel

WARNING Failure to use fuel as recommended in this manual will void the warranty.

- DO NOT use unapproved gasoline such as E85 (85% ethanol/15% gasoline).
- DO NOT mix oil with gasoline.
- DO NOT modify engine to run on alternate fuels.

Mix in a fuel stabilizer when adding fuel to pressure washer to protect fuel system from forming gum deposits. If engine doesn't run properly after fueling, switch fuel brands. The engine is certified to run on gasoline. The emission control system for this engine is EM (Engine Modifications).

WARNING Fuel and fuel vapor are extremely flammable and explosive. Fire or explosion from misuse of fuel can cause severe burns and even death.

WHEN ADDING FUEL TO PRESSURE WASHER, OBSERVE THE FOLLOWING STEPS:

- 2.1 Turn pressure washer OFF and let it cool for at least two minutes before removing fuel cap. Loosen fuel cap slowly to release pressure.
- 2.2 Fill fuel tank outdoors.
- 2.3 DO NOT overfill fuel tank. Leave room for fuel to expand.
- 2.4 Wait for spilled fuel to evaporate before cranking engine.
- 2.5 Keep fuel away from sparks, open flames, pilot lights, heat and other ignition sources.
- 2.6 DO NOT light a cigarette or smoke near open fuel tank or container.
- 2.7 Clean area around fuel fill cap and slowly remove cap to allow any pressure to escape.
- 2.8 Slowly add unleaded gasoline (A) to fuel tank (B). Use extreme caution not to fill fuel above baffle (C). This allow appropriate space for fuel expansion.
- 2.9 Install fuel cap and allow any spilled fuel to evaporate before starting engine.

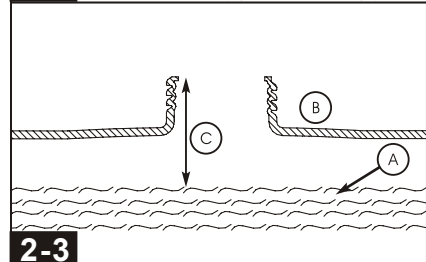
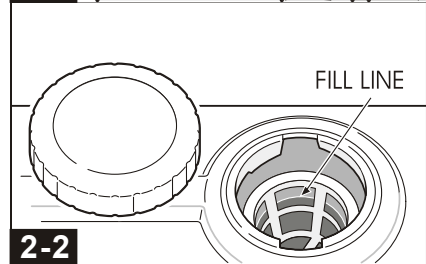
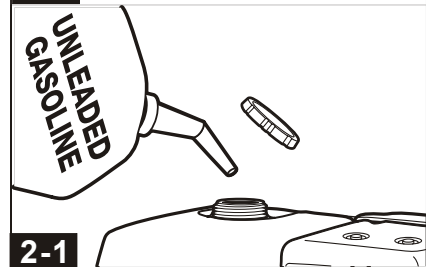
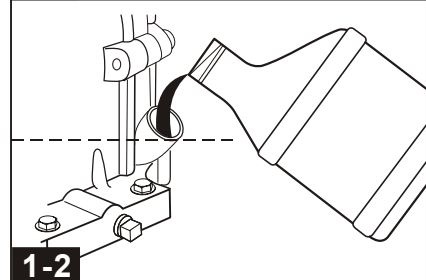
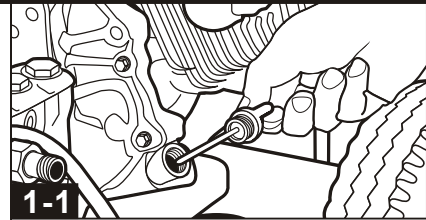

BEFORE USE

3. Attaching High Pressure Hose to Spray Gun

- 3.1 Pull slip ring on female quick-disconnect fitting of high pressure hose back.
- 3.2 Insert male quick-disconnect fitting on spray gun into female quick-disconnect on high pressure hose
- 3.3 Release slip ring on female quick-disconnect and twist. Listen for "click" to ensure both quick-disconnects are coupled.
- 3.4 Pull high pressure hose and spray gun in opposite direction to ensure they do not separate.

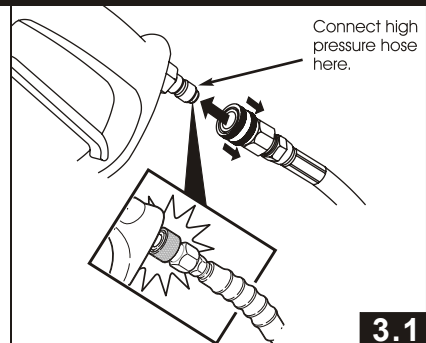

3.1

4. Connecting Spray Wand to Spray Gun

- 4.1 Thread spray wand onto spray gun.

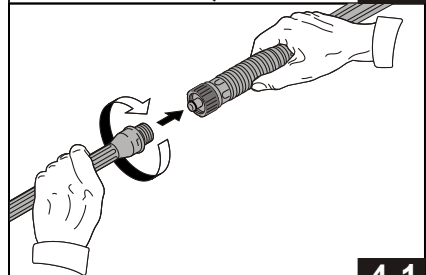

4.1

5. Connect Hose and Water Supply to Pump

- 5.1 Similarly, attach other end of high pressure hose to high pressure outlet on pump. Pull down on collar of quick connect, slide onto pump and let go of collar. Pull on hose to be sure of tight connection.
- 5.2 Before connecting garden hose to water inlet, inspect inlet screen . Clean screen if it contains debris or have it replaced if damaged. DO NOT run pressure washer if inlet screen is damaged.
- 5.3 Run water through your garden hose for 30 seconds to clean out any debris.

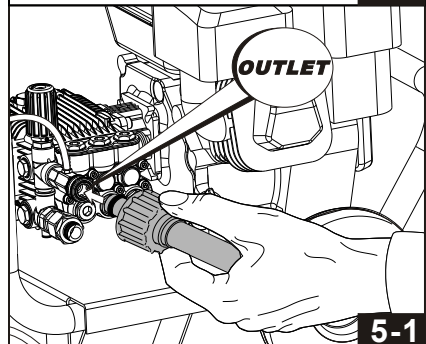

5-1

IMPORTANT: DO NOT siphon standing water for the water supply. Use ONLY cold water (less than 100°F).

- 5.4 Connect the garden hose (not to exceed 50 feet in length and with the ID no less than 13mm) to the water inlet. Tighten by hand.
- 5.5 Turn ON the water, squeeze the trigger to purge the pump system of air and impurities.

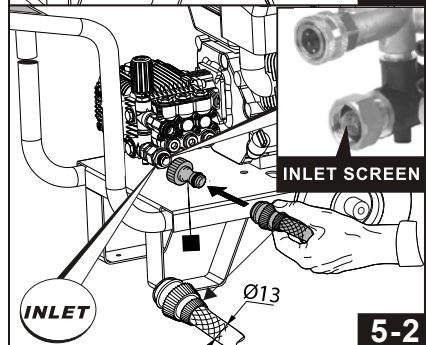

5-2

NOTICE

DO NOT attempt to crank or start the engine before it has been properly serviced with the recommended oil. This may result in an engine failure.

- There MUST be at least ten feet (3 m) of unrestricted garden hose between the pressure washer inlet and any device, such as a vacuum breaker or check valve.
- Damage to equipment resulting from failure to follow this instruction will void warranty.

WARNING

Risk of eye injury.
Spray can splash back or propel objects.



- Always wear safety goggles when using this equipment or in vicinity of where equipment is in use.
- Before starting the pressure washer, be sure you are wearing adequate safety goggles.
- NEVER substitute safety glasses for safety goggles.

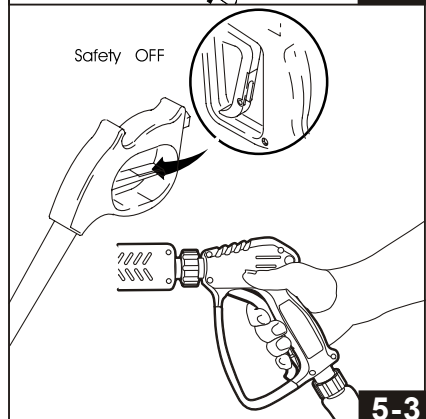

5-3

PRESSURE WASHER LOCATION

Pressure Washer Location

Clearances and Air Movement

⚠ WARNING



- Exhaust heat/gases can ignite combustibles, structures or damage fuel tank causing a fire.

- Keep at least 5 ft. (1.5 m) clearance on all sides of pressure washer including overhead.

Place pressure washer in a well ventilated area, which will allow for removal of deadly exhaust gas. Do not place pressure washer where exhaust gas could accumulate and enter inside or be drawn into a potentially occupied building. Ensure exhaust gas (A) is kept away from any windows, doors, ventilation intakes, or other openings that can allow exhaust gas to collect in a confined area. Prevailing winds and air currents should be taken in

⚠ WARNING



- Running engine gives off carbon monoxide, an odorless, colorless, poison gas.
- Breathing carbon monoxide can cause headache, fatigue, dizziness, vomiting, confusion, seizures, nausea, fainting or death.

- Operate pressure washer ONLY outdoors.
- Keep exhaust gas from entering a confined area through windows, doors, ventilation intakes, or other openings.
- DO NOT start or run engine indoors or in an enclosed area, even if windows and doors are open.

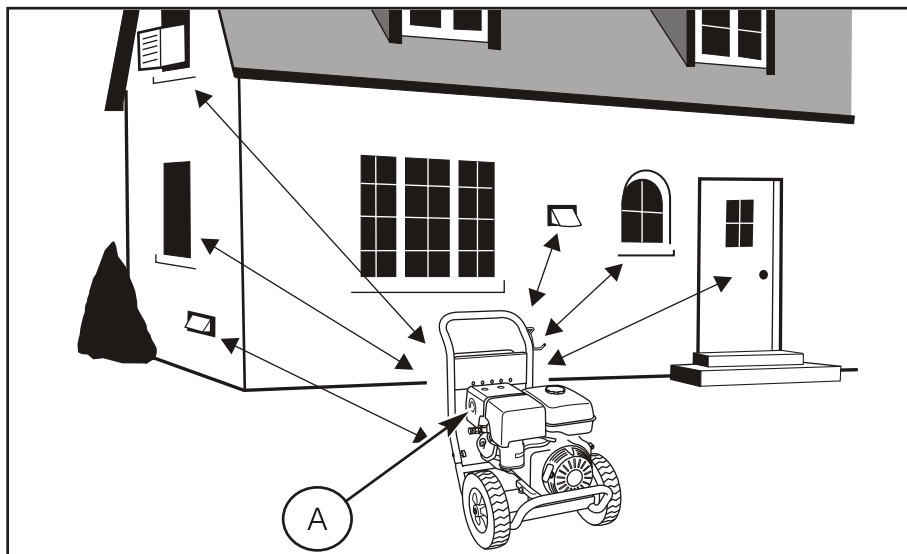

START YOUR POWER WASHER

1. How to Start Your Pressure Washer

To start your pressure washer for the first time, follow these instructions step-by-step. This starting information also applies if you have let the pressure washer sit idle for at least a day.

- 1.1 Place pressure washer near an outside water source capable of supplying water at a flow rate greater than 3.5 gallons per minute and no less than 20 PSI at pressure washer end of garden hose.
- 1.2 Check that high pressure hose is tightly connected to spray gun and pump.
- 1.3 Make sure unit is in a level position.
- 1.4 Uncoil high pressure hose completely before using pressure washer.
- 1.5 Connect garden hose to water inlet on pressure washer pump.
- 1.6 Turn ON water, point gun in a safe direction and squeeze trigger to purge pump system of air and impurities.

NOTICE

DO NOT run the pump without the water supply connected and turned on.

Damage to equipment resulting from failure to follow this instruction will void warranty.

- 1.7 Attach wand to spray gun. Tighten by hand.
- 1.8 Choose the nozzle you want to use, pull back on collar of quick connector, insert nozzle and release collar. Tug on nozzle to make sure it is securely in place.
- 1.9 Rotate fuel shut-off valve to •On• position
- 1.10 Move throttle control lever to •High• Position, shown on engine as a rabbit.
- 1.11 Move choke lever to •Choke• position.

NOTE: For a warm engine, be sure the choke lever is in the •Run• position.

IMPORTANT: Before starting the pressure washer, be sure you are wearing adequate safety goggles.

- 1.12 When starting engine, position yourself as recommended below and grasp starter grip handle and pull slowly until you feel some resistance. Then pull rapidly to start engine.
- 1.13 Return starter grip handle slowly. DO NOT let rope •snap back• against starter.
- 1.14 When engine starts, slowly move choke lever to •Run• position, as engine warms. If engine falters, move choke lever to •Choke• position, then to •Run• position.
- 1.15 After each starting attempt, where engine fails to run, always point gun in safe direction and squeeze spray gun trigger to release high pressure.
- 1.16 If engine fails to start after six pulls, move choke lever to •Run• position, and repeat steps 13 through 15.

2. How to Stop Your Pressure Washer

- 2.1. Release spray gun trigger and let engine idle for two minutes.
- 2.2. Move throttle control lever on engine to •• top• position.
- 2.3. ALWAYS point spray gun in a safe direction, press red button and squeeze spray gun trigger to release retained high water pressure.

IMPORTANT: Spray gun traps high water pressure, even when engine is stopped and water is disconnected.

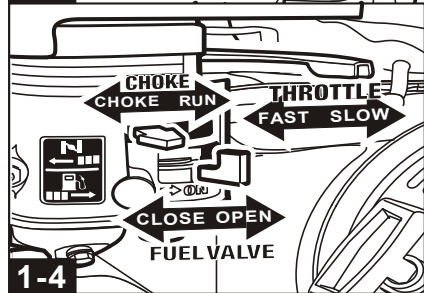
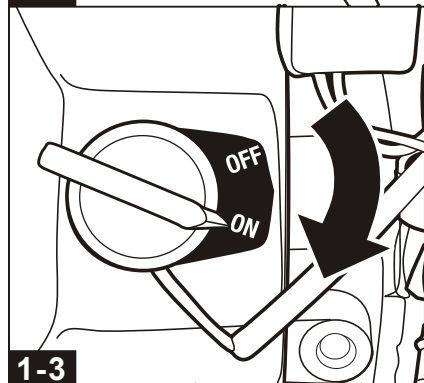
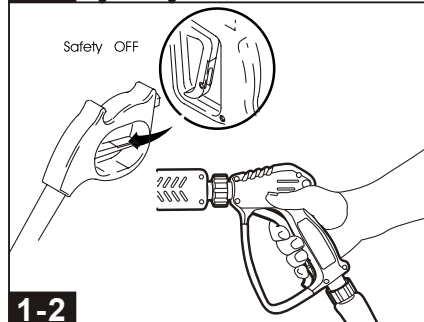
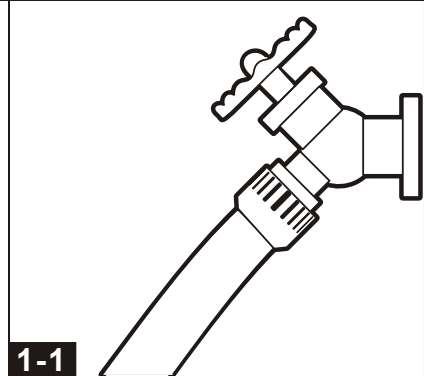

USE THE NOZZLE TIPS

1. Attaching Pressure Nozzles to Spray Wand

- 1.1 Pull slip ring on female quick-disconnect fitting of spray wand back.
- 1.2 Insert male quick-disconnect fitting on pressure nozzle into female quick-disconnect on spray wand.
- 1.3 Release slip ring on female quick-disconnect and twist. Listen for •lick• to ensure both quick-disconnects are coupled.
- 1.4 Pull high pressure nozzle and spray wand in opposite direction to ensure they do not separate.

NOTE

To prevent damage to your surface and to select an appropriate nozzle size for your application, always start with lowest pressure nozzle size (White) and continue changing to the higher nozzle size until the best work result is achieved.

The pressure washer comes furnished with five spray nozzles. Each nozzle is color coded and delivers a specific spray pattern and pressure for a particular cleaning job. The size of the nozzle determines the size of the fan spray and the pressure out of the nozzle.

⚠ WARNING

Pressure washer produces fluid pressures and velocities high enough to penetrate human and animal flesh which could result in serious injury or amputation. Do not point pressure washer in direction of people or animals. High velocity fluid spray can cause objects to break, propelling particles at high speeds.

0° Nozzle - Red: This nozzle delivers a pinpoint stream of pressurized water and is extremely powerful. It covers only a small area of cleaning. This nozzle should only be directed at surfaces that can withstand high pressure such as metal or concrete. Do not use this nozzle to clean wood.

15° Nozzle - Yellow: This nozzle delivers a powerful 15 degree spray pattern for intense cleaning of small areas. This nozzle should only be used on areas and materials that can withstand high pressure.

25° Nozzle - Green: This nozzle delivers a 25 degree spray pattern for intense cleaning of larger areas. This nozzle should only be used on areas that can withstand pressure from this nozzle.

40° Nozzle - White: This nozzle delivers a 40 degree spray pattern and a less powerful stream of water. This nozzle can cover a wide area and should be used for most general cleaning jobs.

Chemical Nozzle - Black: This nozzle is used to apply special chemicals and cleaning solutions. This nozzle produces the weakest pressure stream of the five nozzles.

The pressure washer nozzles are stored in receptacles on a panel mounted to the handle of the washer. Colors on the panel identify nozzle location and spray panel.

2. Interchanging Pressure Nozzles

Turn off pressure washer before attempting to change pressure nozzles.

Follow the steps below:

- 2.1 Pull slip ring off female quick-disconnect back and remove pressure nozzle in pressure wand
- 2.2 Insert male end of new pressure nozzle into quick-disconnect. Release slip ring of quick-disconnect and twist pressure nozzle ensuring proper connection.
- 3.2 Listen for •lick• when coupling quick-disconnect and pull in opposite directions to ensure the quick-disconnect does not come apart.

⚠ WARNING

Never place hands in front of nozzle. Never grasp hose or fittings during pressure washer operation. Never attempt to attach or remove spray wand or hose fittings while pressure washer system is pressurized.

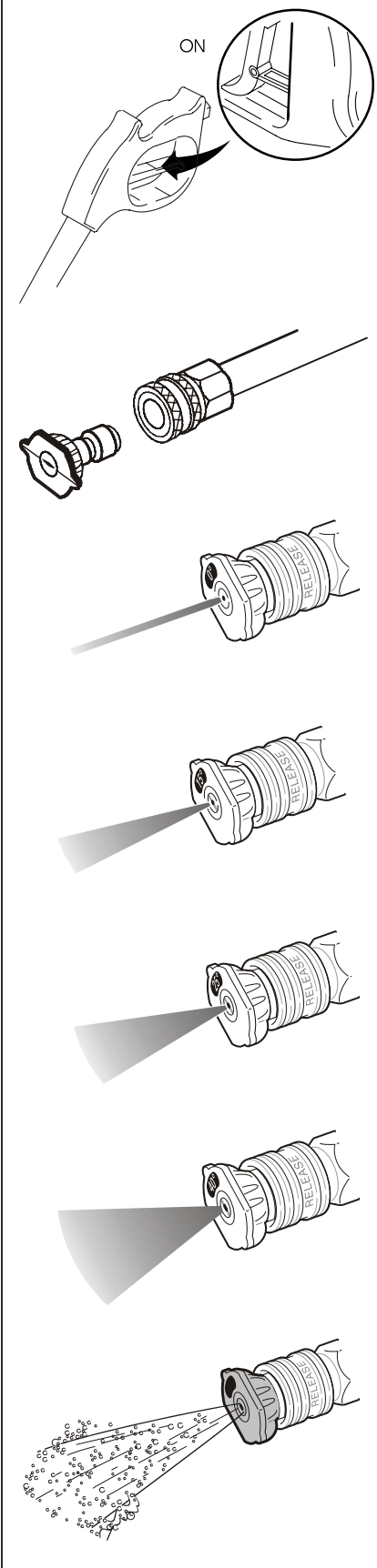

RINSING PRESSURE

1. Pressure Washer Rinsing

- 1.1 Remove black spray tip from nozzle extension.
- 1.2 Select and install desired high pressure spray tip following instructions How to Use Spray Tips.
- 1.3 Keep spray gun a safe distance from area you plan to spray.
- 1.4 Increase (decrease) spray pressure by turning pressure control knob clockwise (counterclockwise). Use lower pressure to wash items such as a car or boat. Use higher pressure to strip paint and degrease driveways.
- 1.5 Apply a high pressure spray to a small area and then check surface for damage. If no damage is found, you can assume it is okay to continue rinsing.
- 1.6 Start at top of area to be rinsed, working down with same overlapping strokes as you used for cleaning.

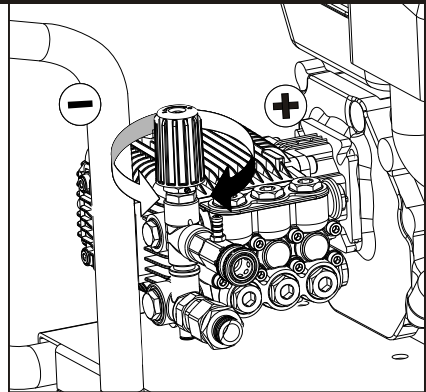

APPLY CHEMICAL

1. To Apply Chemicals:

- 1.1 Press chemical hose onto barbed fitting located near back of high pressure hose connection.
- 1.2 Press other end of chemical hose, with filter, into container holding chemicals or cleaning solutions.
- 1.3 Install chemical (black) nozzle.

2. After Using Chemicals:

- After using soaps and cleaning solutions, it is necessary to thoroughly clean the pressure washer.
- 2.1 Place the chemical hose in a container of clean water.
 - 2.2 Turn on pressure washer and engage spray wand to draw clean water through the system to thoroughly clean it.

3. Cleaning and Applying Detergent

To apply detergent, follow these steps:

- 3.1 Review use of spray tips.
- 3.2 Prepare detergent solution as required by job.
- 3.3 Place small filter end of detergent siphoning tube into detergent container.

NOTE: Make sure the filter is fully submerged in detergent while applying detergent.

4. Make sure black spray tip is installed.

NOTE: Detergent cannot be applied with the high pressure spray tips (White, Green, Yellow or Red).

5. Make sure garden hose is connected to water inlet. Check that high pressure hose is connected to spray gun and pump. Turn on water.
6. Start engine following instructions How to Start Your Pressure Washer.
7. Apply detergent to a dry surface, starting at lower portion of area to be washed and work upward, using long, even overlapping strokes.
8. Allow detergent to "soak in" for 3-5 minutes before washing and rinsing. Reapply as needed to prevent surface from drying. **DO NOT** allow detergent to dry on (prevents streaking).

IMPORTANT: You must flush the detergent siphoning system after each use by placing the filter into a bucket of clean water, then run the pressure washer in low pressure for 1-2 minutes.

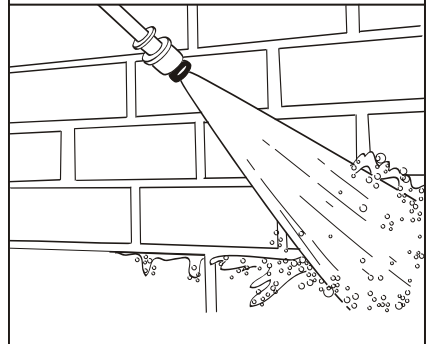
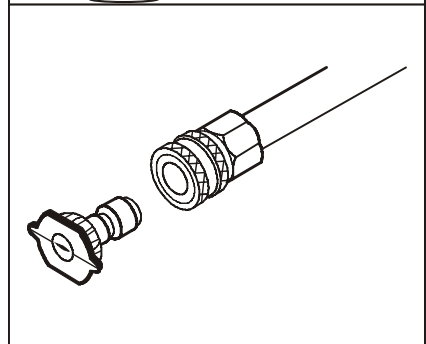
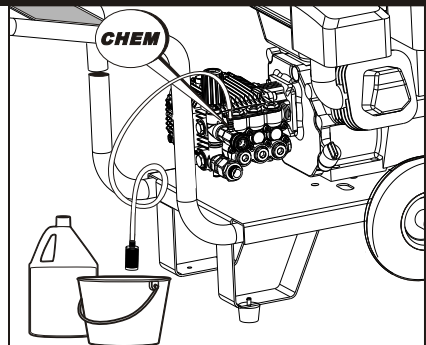

MAINTENANCE

General Recommendations

Regular maintenance will improve the performance and extend the life of the pressure washer.

The pressure washer's warranty does not cover items that have been subjected to operator abuse or negligence. To receive full value from the warranty, the operator must maintain the pressure washer as instructed in this manual and in the engine manual, including proper storage as detailed in Winter Storage and Long Term Storage

NOTE: Should you have questions about replacing components on your pressure washer, please contact dealer for assistance.

- Some adjustments will need to be made periodically to properly maintain your pressure washer. Check the spray gun and extension wand assembly for wear.
- All maintenance in this manual and the engine operator's manual should be made at least once each season.
- Once a year you should clean or replace the spark plug, clean or replace the air filter. A new spark plug and clean air filter assure proper fuel-air mixture and help your engine run better and last longer. Please refer to your engine operator's manual for more details.

Pressure Washer Maintenance

Clean Debris

Daily or before use, clean accumulated debris from cleaning system. Keep linkage, spring and controls clean. Keep area around and behind muffler free from any combustible debris. Inspect cooling air slots and openings on the pressure washer. These openings must be kept clean and unobstructed.

NOTICE

Improper treatment of pressure washer can damage it and shorten its life.

- DONOT insert any objects through cooling slots.

Cleaning system parts should be kept clean to reduce the risk of overheating and ignition of accumulated debris.

Use a damp cloth to wipe exterior surfaces clean.

Use a soft bristle brush to loosen caked on dirt, oil, etc.

Use a vacuum cleaner to pick up loose dirt and debris.

Check and Clean Inlet Screen

Examine the screen on the pump water inlet. Clean it if the screen is clogged or replace it if screen is damaged.

Check High Pressure Hose

The high pressure hose can develop leaks from wear, kinking, or abuse. Inspect the hose each time before using it. Check for cuts, leaks, abrasions or bulging of cover, damage or movement of couplings. If any of these conditions exist, replace the hose immediately.

WARNING



The high pressure stream of water that this equipment produces can cut through skin and its underlying tissues, leading to serious injury and possible amputation.

- NEVER repair high pressure hose. Replace it.
- Replacement hose rating MUST exceed maximum pressure rating of unit

Check Detergent Siphoning Tube

Examine the filter on the detergent tube and clean if clogged. The tube should fit tightly on the barbed fitting. Examine the tube for leaks or tears. Replace the filter or tube if either is damaged.

Check Gun

Examine the hose connection to the spray gun and make sure it is secure, and make sure the •Safety Lock• is present attached on the trigger, it helps to prevent any accident jets when in operating. Replace spray gun immediately if the •Safety Lock• is damage or not works.

Check Spray Wand



Occasionally, the spray wand can become clogged with foreign materials such as dirt. When this happens, excessive pressure can develop. Whenever the pressure nozzle becomes partially clogged, the pump pressure will pulsate. It should be immediately cleaned.

MAINTENANCE

Nozzle Maintenance

A pulsing sensation felt while squeezing the spray gun trigger may be caused by excessive pump pressure. The principal cause of excessive pump pressure is a spray tip clogged or restricted with foreign materials, such as dirt, etc. To correct the problem, immediately clean the spray tip following these instructions:

1. Shut off engine and turn off water supply.
2. ALWAYS point spray gun in a safe direction, squeeze spray gun trigger to release retained high water pressure.

 WARNING	
	<p>The high pressure stream of water that this equipment produces can cut through skin and its underlying tissues, leading to serious injury and possible amputation.</p> <p>Spray gun traps high water pressure, even when engine is stopped and water is disconnected, which can cause injury.</p>
<ul style="list-style-type: none"> • Keep high pressure hose connected to pump and spray gun while system is pressurized. • ALWAYS point spray gun in safe direction squeeze spray gun trigger, to release high pressure, every time you stop engine. 	

3. Remove spray tip from end of nozzle extension.
4. Use a small paper clip to free any foreign material clogging or restricting spray tip (A).

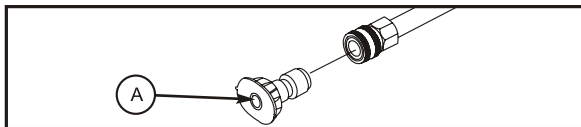

5. Remove nozzle extension from spray gun.
6. Using a garden hose, remove additional debris by back flushing water through nozzle extension. Back flush between

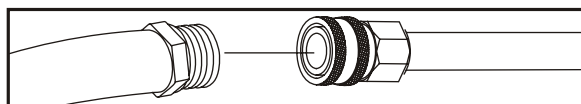

7. Reinstall spray tip into nozzle extension.
8. Reconnect nozzle extension to spray gun.
9. Make sure garden hose is connected to water inlet. Check that high pressure hose is connected to spray gun and pump. Turn on water.
10. Start engine following instructions How to Start Your Pressure Washer
11. Test pressure washer by operating with each quick connect spray tip.

Pump Oil Maintenance

Changing Pump Oil

Change oil after first 50 hours of operation and then every 200 hours or 3 months, whichever occurs first.

NOTE: When changing pump oil, use only high quality nondetergent 30 weight oil. Use no special additives.

Change pump oil as follows:

1. Clean area around brass oil drain plug at bottom of pump.
2. Remove oil drain plug. Drain oil completely into an approved container.
3. When oil has completely drained, install oil drain plug and tighten firmly.
4. Clean area around pump oil dipstick. Remove dipstick and fill pump with recommended oil to full mark on dipstick.
5. Install pump oil dipstick.
6. Wipe up any spilled oil.

Pump Series	Oil Type	Oil Capacity
15	10W-30	500ML
18	10W-30	600ML

Engine Maintenance

See the engine operator's manual for instructions on how to properly maintain the engine.

 CAUTION	
Avoid prolonged or repeated skin contact with used motor oil.	
<ul style="list-style-type: none"> • Used motor oil has been shown to cause skin cancer in certain laboratory animals. • Thoroughly wash exposed areas with soap and water. 	



KEEP OUT OF REACH OF CHILDREN. DON'T POLLUTE. CONSERVE RESOURCES. RETURN USED OIL TO COLLECTION CENTERS.

STORAGE

Long Term Storage Instructions (Fuel in tank)

Gasoline fuel can become stale when stored over 30 days. Stale fuel causes acid and gum deposits to form in the fuel system or crucial carburetor parts. To keep fuel fresh, add a fuel stabilizer liquid additive to fuel. The fuel stabilizer is available at most auto parts stores.

Draining gasoline is unnecessary if the fuel stabilizer is used according to the instructions that come with it. Run pressure washer engine for a minimum of two minutes, after stabilizer is added to fuel, to allow it to circulate throughout the engine. The engine and fuel can be stored up to 24 months.

⚠ WARNING Fuel and fuel vapor are extremely flammable and explosive. Fire or explosion from misuse of fuel can cause severe burns and even death.

To Protect Against Rust Formation During Storage, Oil the Cylinder Bore:

1. Remove spark plug and pour approximately 1/2oz (15 ml) of clean engine oil into the cylinder.
2. Install spark plug and pull starter handle slowly to distribute oil. DO NOT start engine at this time.
3. Slowly pull the recoil starter 2 to 3 times to distribute and coat the cylinder bore with oil.

⚠ WARNING
Unintentional sparking can cause fire or electrical shock. Failure to observe this warning can cause severe property damage, severe burns and even death.
Disconnect spark plug wire from spark plug and cover tip of spark plug wire with insulating tape and place wire where it cannot come in contact with spark plug or pressure washer frame.

Storage of Pressure Pump

1. Drain all water from high pressure line, coil it and store it in cradle of pressure washer handle.
2. Drain all water from spray gun and spray wand by holding spray gun in vertical position with nozzle pointed downward. Squeeze trigger to remove fluids from spray gun and spray wand. Store in spray gun/hose holder.

3. Store chemical hose, high pressure hose and spray wand so they are protected from damage, such as being run over.

It is **RECOMMENDED** that you follow these steps to protect the internal seals of pressure washer when storing unit for more than 30 days and/or when freezing temperatures are expected.

1. Obtain a funnel, six ounces of RV antifreeze and approximately 36 inches of garden hose with a male hose connector on one end.

⚠ CAUTION

Use only RV antifreeze. Any other type of antifreeze is corrosive and can damage pressure pump.

2. Disconnect spark plug wire. Ensure it cannot touch any metal on pressure washer.
3. Connect 36 inch length of garden hose to water inlet of pressure pump.
4. Add RV antifreeze.
5. Pull engine starter rope slowly several times until antifreeze comes out of pressure hose connection of pressure pump.
6. Remove hose from water inlet of pressure pump.
7. Reconnect spark plug wire.

Other Storage Tips

1. DO NOT store gasoline from one season to another unless it's been treated with fuel stabilizer.
2. Replace fuel container, if metal, and it begins to rust. Rust and dirt and debris can contaminate fuel supply and components resulting in poor performance and/or internal damage to engine. Fuel should be stored in newer approved plastic storage containers.
3. Cover pressure washer with a suitable cover that does not retain moisture such as a plastic or plastic coated tarp.
4. Store pressure washer in a clean, dry area.

⚠ WARNING

Certain storage covers can be flammable or can melt in higher temperatures. Do not place storage cover over pressure washer unit until it has completely cooled.

TROUBLE SHOOTING GUIDE

Problem	Probable Cause	Solution
Engine shuts down when running.	<ol style="list-style-type: none"> 1. Out of fuel. 2. Low Engine Oil 	<ol style="list-style-type: none"> 1. Fill fuel tank. 2. Add oil.
Engine will not start; or starts and runs rough.	<ol style="list-style-type: none"> 1. Rocker switch set to 2. Fuel valve is in "OFF" position. 3. Dirty air cleaner 4. Out of fuel. 5. Stale fuel. 6. Spark plug wire not connected to spark plug. 7. Bad spark plug. 8. Water in fuel. 9. Flooded. 10. Excessively rich fuel/air mixture. 11. Intake valve stuck open or closed. 12. Engine has lost compression. 13. Low engine oil. 14. Wrong Fuel. 15. Engine is too hot 16. Chock is in wrong position 17. Pressure Builds up after 2 pulls on recoil starter or after initial use. 	<ol style="list-style-type: none"> 1. Set switch to "ON" position. 2. Turn fuel valve to "ON" position. 3. Clean or replace air cleaner 4. Fill fuel tank. 5. Drain fuel tank and carburetor; fill with fresh fuel. 6. Connect wire to spark plug. 7. Replace spark plug. 8. Drain fuel tank and carburetor; fill with fresh fuel. 9. Wait 5 minutes and re-crank engine. 10. Contact authorized service facility. 11. Contact authorized service facility. 12. Contact authorized service facility. 13. Add oil. 14. Use recommended fuel. 15. Allow engine to cool 16. Change chock position 17. Squeeze gun trigger to relieve pressure.
Engine "Hunts" or falters.	<ol style="list-style-type: none"> 1. Carburetor is running too rich or too lean. 	<ol style="list-style-type: none"> 1. Contact authorized service facility.
Engine lacks power.	<ol style="list-style-type: none"> 1. Cylinder pressure is low. 2. Dirty air cleaner 	<ol style="list-style-type: none"> 1. Contact authorized service facility. 2. Replace air filter.
No pressure or Low pressure.	<ol style="list-style-type: none"> 1. Spray wand not set to high pressure. 2. Lower water supply. 3. Hose fitting leaks during high pressure. 4. Nozzle obstructed. 5. Water filter screen obstructed. 6. Defective thermal relief valve. 7. Air in hose. 8. Choke lever in choke position. 9. Throttle control lever is hot in fast position. 10. High pressure too long. 	<ol style="list-style-type: none"> 1. See "Using Spray Wand" section. 2. Water supply must be 5 GPM @ 20 psi. 3. Tighten hose fitting. Use thread sealant tape if necessary. 5. Remove and clean filter. 6. Call Customer Service: 7. Stop engine and water source. Disconnect water source from pump inlet and turn water source to ON to remove all air from hose. When steady stream of water is present, turn water source to OFF. Re-connect water source to pump inlet and turn on water source. Squeeze trigger to remove remaining air. 8. Move choke to NO CHOKE position. 9. Move throttle control lever from fast position. 10. Use High pressure hose under 100 ft (305 M).

TROUBLE SHOOTING GUIDE

Problem	Probable Cause	Solution
Pump will not draw Chemicals	<ol style="list-style-type: none"> 1.Spray wand not set to low pressure.. 2.Chemical filter clogged. 3.Chemical screen not in chemical. 4.Chemical solution too thick. 5.Pressure hose too long 6.Chemical build-up in chemical injector. 	<ol style="list-style-type: none"> 1.See "Using Spray Wand" section. 2.Clean Filter. 3.Ensure end of chemical hose is fully submerged into chemicals. 4.Dilute chemical. Chemical solutions should have same consistency as water. 5.Lengthen water supply hose instead of pressure hose. 6.Have parts cleaned or replaced by authorized dealer.
No or low pressure (after period of normal use).	<ol style="list-style-type: none"> 1.Worn seal or packing. 2.Worn or obstructed valves. 3.Worn unloader piston. 4.Worn E-Z start valve. 	Have parts cleaned or replaced by authorized dealer.
Water leaking at spray gun/spray wand connection.	<ol style="list-style-type: none"> 1.Worn or broken O-ring. 2.Loose hose connection. 	<ol style="list-style-type: none"> 1. Check and replace O-ring. 2. Tighten hose connection.
Water leaking at pump.	<ol style="list-style-type: none"> 1.Loose connections. 2.Piston packings worn. 3.Worn or broken O-rings. 4.Pump head or tubes damaged from freezing. 	<ol style="list-style-type: none"> 1.Check and replace O-ring 2.Tighten hose connection. 1.Tighten connections. 2.Have parts cleaned or replaced by authorized dealer. 3.Have parts cleaned or replaced by authorized dealer. 4.Have parts cleaned or replaced by authorized dealer.
Oil leaking at pump	<ol style="list-style-type: none"> 1.Oil seals worn. 2.Loose drain plug. 3.Worn drain plug O-ring. 4.Worn fill plug O-ring. 5.Pump overfilled. 6.Incorrect oil used. 7.Vent plug clogged. 	<ol style="list-style-type: none"> 1. Have parts cleaned or replaced by authorized dealer. 2.Tighten drain plug. 3.Inspect and replace O-ring. 4.Inspect and replace O-ring. 5.Check for correct amount. 6.Drain and refill with correct type and amount of oil. 7.Clean vent plug. Use air hose to free it of blockage. If problem persists, replace vent plug.
Pump pulsates	Nozzle obstructed.	See "Using Spray Wand" section.

UNIT EXPLODED VIEW AND PARTS LIST

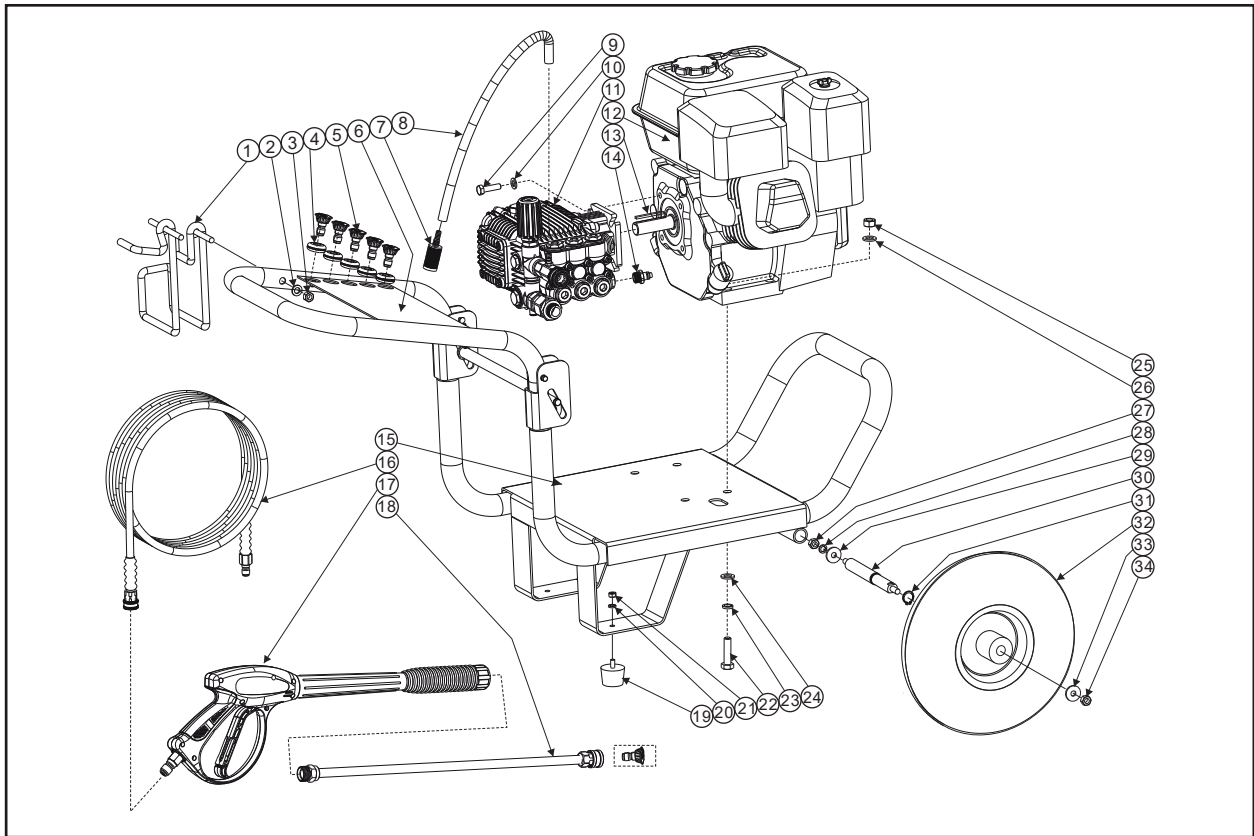

PARTS LIST

Ref No.	Description	Qty per pump	Ref No.	Description	Qty per pump
1	Gun holder and hose hook	1	18	Wand	1
2	Plain washer	1	19	Rubber foot	2
3	Fix nut	1	20	Plain washer	2
4	Grommet	5	21	Fix nut	2
5	Nozzle set	5	22	Engine fix bolt	4
6	Decal	1	23	Spring washer	4
7	Filter	1	24	Plain washer	4
8	Chemical inlet hose	1m	25	Fix nut	4
9	Pump fix bolt	4	26	Spring washer	4
10	Spring washer	4	27	Axile fix nut	2
11	Axial pump assy	1	28	Spring washer	2
12	Engine	1	29	Plain washer	2
13	Key	1	30	Axile	2
14	Thermal protect valve	1	31	Clip	2
15	Frame	1	32	Wheel	2
16	High-pressure hose	10m	33	Plain washer	2
17	Spray gun	1	34	Wheel fix nut	2

PUMP EXPLODED VIEW AND PARTS LIST

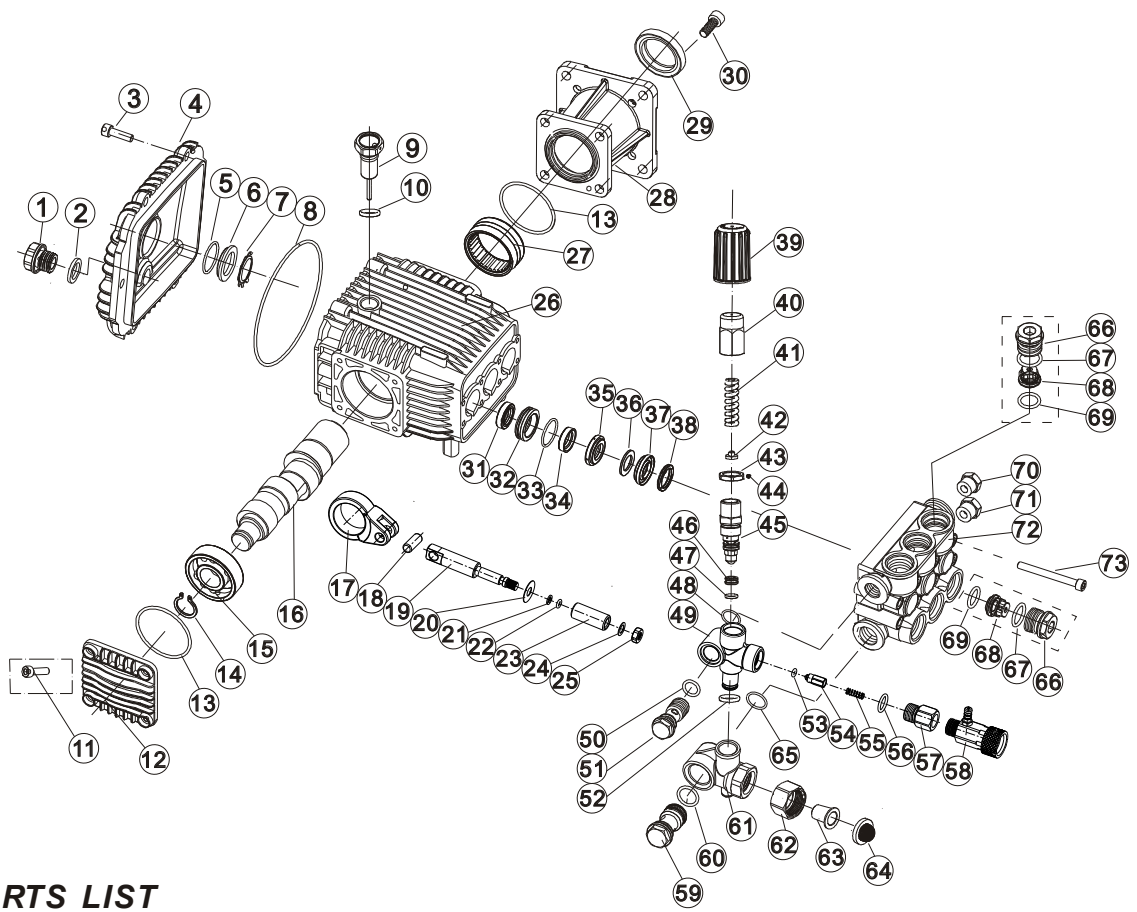

PARTS LIST

1	Drain plug	26	Crankcase	51	Outlet banjo bolt
2	Gasket 17.5x12x2	27	Needle bearing 4907	52	O-ring 11.3x2.4
3	Screw	28	Flange	53	O-ring
4	Crankcase cover	29	Oil seal 40x52x7	54	Checking valve
5	O-ring 20.4X2.4	30	Bolt M8x20	55	Spring
6	Side glass	31	Oil seal	56	O-ring
7	Fix clip	32	Retainer ring	57	Outlet connector
8	O-ring 104X3	33	O-ring 26.7x1.78	58	QD with detergent injection
9	Vented oil plug	34	Low pressure seal	59	Inlet banjo bolt
10	O-ring 11.6X2.4	35	Seal compaction ring	60	O-ring 18.2x2.4
11	Bolt M8x16	36	Seal Compaction flake	61	By-pass housing
12	Crankshaft cover	37	High-pressure seal	62	Swivel nut
13	O-ring 51.8x2.2	38	Supporting ring	63	Inlet connector
14	Snap ring	39	Plastic cap	64	Inlet water filter
15	Ball bearing 6304	40	Knob	65	O-ring 23.4x2.4
16	Crankshaft	41	Spring	66	Valve Plug
17	Connecting rod	42	Spring seat	67	O-ring 18x2.65
18	Fix pin	43	Jam nut	68	Checking valve assy
19	Plunger guide	44	Fix screw M4x4	69	O-ring 15.54x2.62
20	Checking ring	45	Unloader Valve	70	Outlet plug
21	Backup ring	46	Valve Seat	71	Inlet plug
22	O-ring	47	O-ring 9.25x1.78	72	Manifold head
23	Ceramic pipe	48	O-ring 18.2x2.4	73	Bolt M8x60
24	Plain washer	49	Valve housing		
25	Fix nut	50	O-ring 18.2x2.4		



Recycling



ENVIRONMENTAL PROTECTION: Please recycle any unwanted materials as opposed to disposing them as general waste. It is recommended the original is retained and used to store the product when not in use for prolonged periods of time. If this is not applicable ensure the materials are sorted and recycled in accordance with local regulations.



SPECIFICATION CHANGE: It is our policy to continually improve products to ensure these meet the rigours of the industry we serve. Therefore, as such we reserve the right to alter specifications, data, components & parts with-out prior notice.

WARRANTY: Please refer to the manufactures terms & conditions.

IMPORTANT: No liability will be accepted for the incorrect use of this product.

KEEP THIS BOOKLET FOR FUTURE REFERENCE

📞 Nottingham: 0115 946 1988 • London: 0208 830 3333 ✉ Nottingham: sales@hscgroupuk.co.uk • London: sean@hscgroupuk.co.uk 🌐 www.hscgroupuk.co.uk

The Hire Supply Company Terms & Conditions Apply At All Time E&OE